

PowerBoss™ SW/88

A Big, Rugged Sweeper for Tough Applications



- The 60-inch sweep path handles up to four acres per hour
- Sixteen cubic foot hopper holds 1200 pounds of trash and debris
- Choice of multi-level high-dump (with RTM™) or low-dump



RTM™ Rotary Trash Relocator comes standard with all high-dump models. Operator spends more time sweeping, not dumping.

PowerBoss™ SW/88 POWER FEATURES



There's more to do than just sweep. The PowerStacker™ option turns your sweeper into a forklift.



An optional blower attachment activated from operator seat makes the SW/88 even more versatile. Blows debris from hard-to-reach spots into sweeping path. A vacuum attachment is also available.



Positive-sealed quick-change panel filters remove in less than five minutes without tools. Electric shakers clean filters as needed without removal.

- Efficient and effective direct-throw sweeping
- Reliable hydraulic drives with premium, easy-to-service components
- Transverse mid-engine design for stability and ease of access
- Rugged one-piece unitized frame
- Heavy-duty, 4-cylinder, liquid-cooled engine provides efficient power
- Many options available to meet your needs

GENERAL SPECIFICATIONS

Subject to change without notice.
(Metric shown in parentheses.)

ENGINE - Transverse mid-engine design. 49 HP (36.3 kW). 4-cylinder, liquid-cooled gasoline engine develops 38 HP (28.3 kW) at governed 2600 RPM. Electric start 12-volt battery. Eight-gallon (30.2 liters) gas tank with electric fuel gauge. L.P. gas optional. Diesel option: 46 HP (34.3 kW). 4-cylinder, liquid-cooled.

FRAME - Unitized construction featuring 3/16 in. (4.8 mm) steel plate; reinforced at stress points.

DRIVES - Hydraulically-driven rear wheel. Variable speeds to 10 MPH (16.09 km/h). Main broom, side broom, and hopper dump are hydraulically operated. Vacuum impeller is belt-driven off engine at constant RPM.

STEERING - Standard automotive cam-and-lever steering through rear wheel.

SWEEP PATH - 60-in. (1270 mm) sweep path including side brush.

SWEEPING COVERAGE - 178,000 sq. ft. (16536 m²) per hour based on a 60-in. (1270 mm) path at 7-1/2 MPH (12.07 km/h) with 6-in. (152 mm) overlap.

SWEEPING BRUSHES - Main broom: Cylindrical, one-piece disposable runs at constant RPM, five minute broom change. Raised and lowered from operator compartment. Floats for uneven surfaces. Adjustment for pressure, wear. Side broom: Rotary, one-piece disposable. Quick change in seconds. No tools required. Bumper protected. Adjustment for angle, pressure and wear.

VACUUM SYSTEM - Fully-enclosed, positive-sealed, quick-change panel filters. 120 sq. ft. (11.15 m²) of filtering area. High volume 9-in. (228 mm) impeller provides constant air flow. Air is expelled outside engine compartment. Filters cleaned with two electric shakers.

DEBRIS HOPPER - 16 cu. ft. (45 m³); holds up to 1200 lbs. (544 kg). Low-dump or multi-level high-dump (up to 60 in. (1524 mm)).

CONTROLS - Operator controls all functions of sweeping and debris disposal while seated. Instant forward, reverse and braking using one pedal. Foot pedal activated emergency/parking brake.

INSTRUMENTS - Ammeter, hour meter, fuel gauge, oil pressure, water temperature.

TIRES - Front are 16-in. (406 mm) O.D. industrial solid. Rear is 16-in. (406 mm) O.D. industrial solid.

WEIGHT - Net: 2800 lbs. (1270 kg); Shipping: 3200 lbs. (1451 kg).

DIMENSIONS - Length: 104.37" (2651 mm). Width: 60.12" (1527 mm) (to side broom guard). Height: 57.07" (1447 mm) (with overhead guard). 67.07" (2209 mm) H. (with cab: 63.90" (2120 mm) H.).

OPTIONAL EQUIPMENT - See Options Specification Sheet.

WARRANTY - Eighteen months or 1500 hours on all parts and components, except normal wear items. First 90 days includes labor. See LIMITED PRODUCT WARRANTY for complete warranty details.

SW88/055 Copyright AAR BROOKS & PERKINS CORP. 1995

MANUFACTURED BY

AAR BROOKS & PERKINS
HANDLING TECHNOLOGIES DIVISION
P.O. BOX 1227/ABERDEEN, NC 28315
919-944-2167/TWX 510-939-3392
TOLL-FREE: 1-800-334-7141



SOLD AND SERVICED BY

PowerBoss™ Sweeper

OPERATION & MAINTENANCE MANUAL

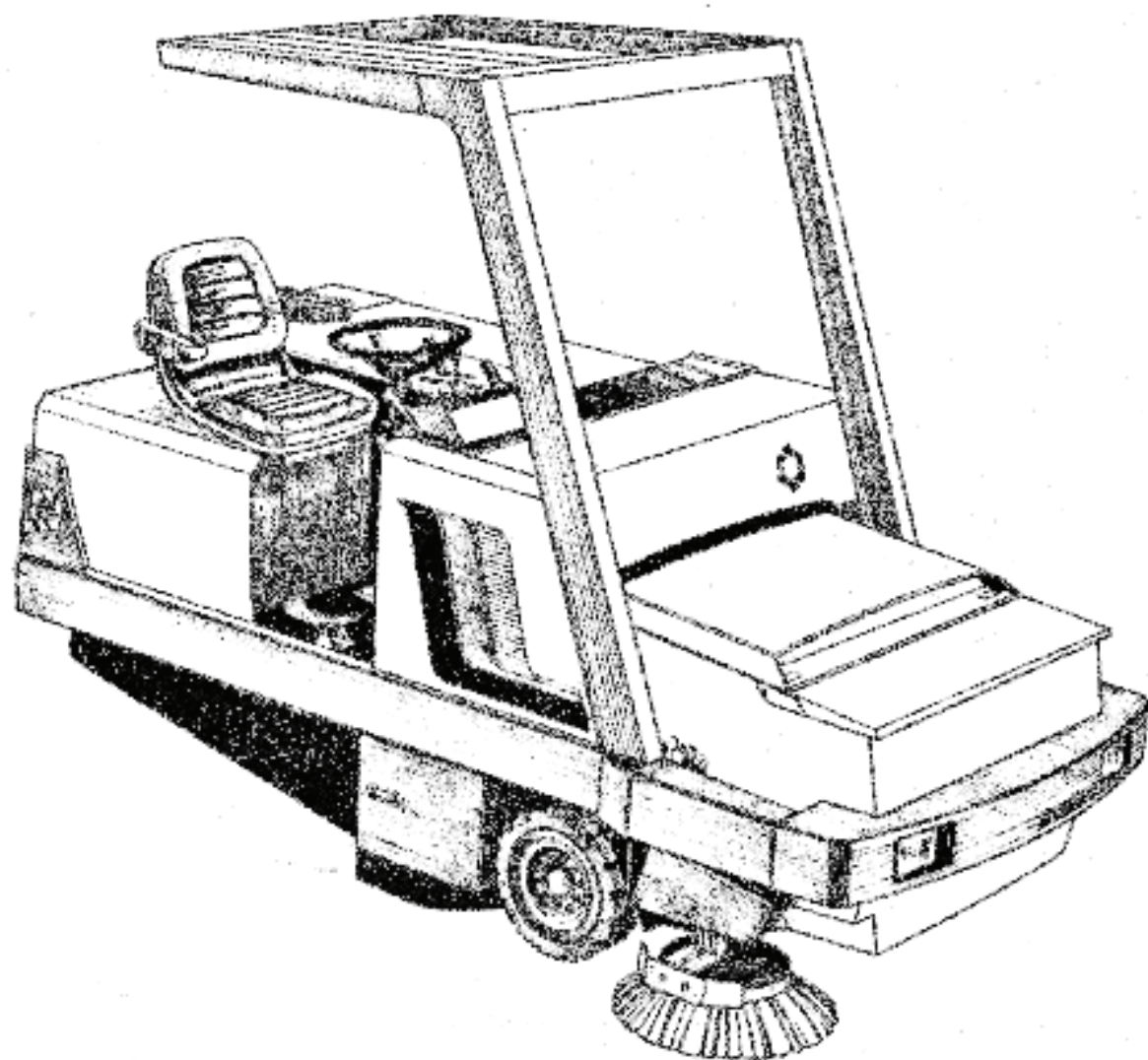

AAR Brooks & Perkins

TABLE OF CONTENTS

POWERBOSS™ SWEEPER

OPERATION AND MAINTENANCE MANUAL

What You Will Find in This Manual.....	i
INTRODUCTION	
Introducing PowerBoss™ Sweepers.....	A-1
Special Features.....	A-2
Your PowerBoss™ Sweeper.....	A-3
SAFETY	
Safety Symbols.....	B-1
Safety Decals.....	B-2
Basic PowerBoss™ Safety.....	B-3
SPECIFICATIONS	
SW 68.....	C-1
SW 78.....	C-3
COMPONENT DESCRIPTIONS	
The Engine.....	D-1
The Air Intake System.....	D-1
The Electrical System.....	D-2
The Fuel System.....	D-3
The Coolant System.....	D-3
The Lubrication System.....	D-4
The Hydraulic Systems.....	D-4
The Vacuum System.....	D-5
Sweep Components.....	D-5
Hoppers.....	D-6
Steering, Brakes, and Tires.....	D-6

OPERATION

Basic Operating Controls.....	E-1
Sweeping Controls.....	E-3
Debris Hopper Dump Controls.....	E-6
Operating Procedures.....	E-7
Pre-Operation Checks.....	E-7
Starting.....	E-7
Slowing and Stopping.....	E-7
Operating on Grades.....	E-10
Sweeping.....	E-10
Emptying the Hopper.....	E-10
Using the Rotary Trash Collector.....	E-12
Transporting the Machine.....	E-13
Using the Accessories.....	E-13

MAINTENANCE

Introduction.....	F-1
Preventive Maintenance Chart.....	F-2
Engine.....	F-6
Air Intake and Exhaust Systems.....	F-7
Air Filter Removal.....	F-7
Air Filter Cleaning.....	F-8
Air Filter Inspection.....	F-8
Air Filter Installation.....	F-8
Electrical System.....	F-10
Electrical Schematic.....	F-10
Battery Cleaning.....	F-11
Battery Replacement.....	F-12
Fuse Replacement.....	F-12

Fuel System	F-13
Checking the LPG Fuel Filter Lock.....	F-14
Draining the Kubota Water Trap.....	F-14
Replacing the Kubota Fuel Filter Element.....	F-15
Priming the Kubota Fuel System.....	F-15
Cleaning the Perkins Water Trap.....	F-16
Replacing the Perkins Fuel Filter Element.....	F-16
Priming the Perkins Fuel System.....	F-16
Coolant System	F-17
Blowing Out Radiator Fins.....	F-17
Reverse Filter Flushing.....	F-17
Lubrication	F-19
Changing Engine Oil.....	F-20
Lubrication Points.....	F-21
Lubrication Chart.....	F-22
Hydraulics System	F-25
Filling the Fluid Reservoir.....	F-25
Maintaining Cooling Coil Efficiency.....	F-26
Changing the Hydraulic Fluid.....	F-26
Changing the Hydraulic Fluid Filter.....	F-27
Adjusting the Directional Control Return Spring.....	F-27
Adjusting Machine Speed.....	F-29
Hydraulic Schematic	F-30
SW 76 Multi-Level Dump.....	F-31
SW 76 Low Dump.....	F-32
SW 88 Multi-Level Dump.....	F-33
SW 88 Low Dump.....	F-34

Vacuum System	F-35
Belt Tensioning	F-35
Pulley Realignment	F-38
Lubrication of Impeller Sealing Housings	F-39
Sweep Components	F-40
Broom Door Flap Inspection	F-40
Broom Door Flap Replacement and Adjustment	F-41
Main Broom Adjustment Test	F-41
Main Broom Adjustment	F-42
Main Broom Taper Adjustment	F-43
Side Broom Adjustment Inspection	F-45
Side Broom Height (Wear) Adjustment	F-45
Side Broom Angle Adjustment	F-46
Side Broom Lift Cable Adjustment	F-47
Main Broom Replacement	F-47
Side Broom Replacement	F-48
Hoppers	F-50
Low Dump Hopper Removal and Replacement	F-50
High Dump Hopper Removal and Replacement	F-52
Filter Removal	F-52
Filter Cleaning	F-52
Filter Replacement	F-54
Hopper Floor Clearance and Dump Adjustments	F-55
Adjusting Low Dump Maximum Hopper Dump Angle	F-55
Hopper Vacuum Gasket Mount Adjustment	F-56
Hopper Flap Replacements	F-58
Hopper Frame Seal Replacement	F-58
Steering	F-60
Parking Brake	F-61
Parking Brake Adjustment	F-61

Tires	F-22
Inflation	F-22
Changing Solid Tires	F-22
Changing Pneumatic Tires	F-22
Miscellaneous Adjustments	F-23

TROUBLESHOOTING

Basic Machine Operating Problems	G-1
Sweeping Problems	G-2
Hydraulic System Problems	G-4

PARTS

To Order Parts and Supplies	H-1
Frame	H-3
Engine Cycles	H-5
Miscellaneous Engine	H-7
Donaldson Air Cleaner	H-11
Exhaust System	H-13
Battery	H-15
Instrument Panel	H-17
Fuel System	H-19
Miscellaneous Radiators, Shrouds, and Mounts	H-21
Fuel Radiators, Shrouds and Mounts	H-23
Hydraulic Reservoir	H-25
Hydraulic Valves	H-27
Directional Control	H-29
Cooling Coil	H-31
85 Series Impeller	H-33
75 Series Impeller	H-35
Main Drive	H-37

Side Broom.....	H-36
Hopper.....	H-41
High Dump Arm Assembly.....	H-43
Bumpers and Low Dump Arm Assembly.....	H-45
High Dump Safety Arm.....	H-47
Onlites.....	H-49
Low Dump Hopper Shut-off.....	H-51
Steering.....	H-53
Axis, Brakes and Wheel.....	H-55

OPTIONS

To Order Parts and Supplies.....	I-1
Ford Gas Engine.....	I-3
Perkins Diesel Engine.....	I-5
Kubota Diesel Engine.....	I-9
Cab.....	I-11
Overhead Guard.....	I-13
Windshield Wiper.....	I-15
Heater/Detroiler.....	I-17
Pressurizer.....	I-19
Hopper Fire Indicator.....	I-21
Clogged Filter Indicator.....	I-23
Light Options.....	I-25
Power Packer High Dump Assembly.....	I-27
Powerstack Group.....	I-31
Blower Option.....	I-33
Vacuum Wand.....	I-35
Vacuumized Curb Broom (Hood Detail).....	I-37
Vacuumized Curb Broom (Hopper Detail).....	I-39
Heavy Duty Curb Broom Guard.....	I-41

Hot Sweep Bypass.....143

Niche In The Assembly.....145

WHAT YOU WILL FIND IN THIS MANUAL

Introduction	The Introduction lists the PowerBoss™ sweeper models and summarizes special features which they possess.
Safety	The Safety section provides information and rules for the safe operation and maintenance of the sweeper.
Specifications	The Specifications section lists key specifications of each model, indicating capacities, capabilities, and other basic information.
Component Descriptions	The Component Description section provides a brief summary of each component or system, including specific descriptions where applicable.
Operation	The Operation section explains the basic controls and accessory controls on PowerBoss™ sweepers and instructions for operation.
Maintenance	The Maintenance section contains preventive maintenance charts and service instructions for required maintenance tasks.
Troubleshooting	The Troubleshooting section contains a troubleshooting chart to assist you in identifying and correcting problems which may occur during the operation of your equipment.
Parts	The Parts section contains parts lists and exploded views of all machine components.
Options	The Options section contains parts lists and exploded views of all machine options.
Engine	The Engine section contains engine manufacturer's maintenance manual and specification sheets.

**Hydraulic
Components**

The Hydraulic Components section contains manufacturer's specification sheets and maintenance procedures.

Miscellaneous

The Miscellaneous section contains additional information on machine components.

TABLE OF CONTENTS
Introduction

Introducing PowerBoss™ Sweepers.....A-1

Special Features.....A-2

Your PowerBoss™ Sweeper.....A-3

INTRODUCING POWERBOSS™ SWEEPERS

This manual contains information required for the operation and maintenance of the following PowerBoss™ sweepers:

SW 88
SW 78

WARRANTY

See LIMITED PRODUCT WARRANTY at the back of this manual for complete warranty details.

SPECIAL FEATURES

Regardless of the and size sweeper you own or operate, you will enjoy all of the following features:

- rugged one-piece unitized frame
- reliable hydraulic drive with easy-to-service components
- high and effective direct-throw sweeping
- standard or high capacity hoppers with or without dust control
- rear wheel drive/steering for exceptional maneuverability
- four cylinder, liquid-cooled engine
- transverse mid-engine design, providing stability and accessibility for maintenance
- quick-release side broom for quick removal and change
- floating brooms for uneven surfaces

YOUR POWERBOSS™ SWEEPER

Most of the information in this manual applies to both models unless it is otherwise specified. Read this sheet and note the particular features of your PowerBoss™ Sweeper indicated by checkmarks. Then you can determine which information in this manual does not apply to your machine.

MODEL	<input type="checkbox"/> SW 78 <input type="checkbox"/> SW 88	ENGINE	<input type="checkbox"/> gasoline <input type="checkbox"/> LPG <input type="checkbox"/> Diesel
HOPPER	<input type="checkbox"/> Manual Lift Out <input type="checkbox"/> Low Dump <input type="checkbox"/> Multi-Level High Dump	TIRES	<input type="checkbox"/> Michelin Pneumatic <input type="checkbox"/> Solid <input type="checkbox"/> Solid Soft Shoe <input type="checkbox"/> Solid Nonmarking
SPECIAL FEATURES	<input type="checkbox"/> Power Packer <input type="checkbox"/> Power Stacker <input type="checkbox"/> Rotary Trash Relocator <input type="checkbox"/> Blower Attachment <input type="checkbox"/> Vacuum Wand Attachment <input type="checkbox"/> Snow Plow <input type="checkbox"/> Bucket Attachment <input type="checkbox"/> Overhead Guard <input type="checkbox"/> Hopper Dolly <input type="checkbox"/> Lights <input type="checkbox"/> Cab <input type="checkbox"/> Cab Heater <input type="checkbox"/> Cab Defroster/Fan <input type="checkbox"/> Windshield Wiper <input type="checkbox"/> Cab Air Pressurizer <input type="checkbox"/> Fire In Hopper Indicator <input type="checkbox"/> Clogged Filter Indicator	MAIN BROOM BRISTLES	<input type="checkbox"/> Nylon <input type="checkbox"/> ProX <input type="checkbox"/> ProX and Wire <input type="checkbox"/> Natural Fiber <input type="checkbox"/> Pure Nylon <input type="checkbox"/> Steel <input type="checkbox"/> Union Fiber & Wire Mix

TABLE OF CONTENTS
Safety

Safety Symbols.....	B-1
Safety Decals.....	B-2
Basic PowerBoss™ Safety.....	B-8

SAFETY SYMBOLS

Five symbols are used throughout this manual to emphasize various levels of safety information. These symbols and the meaning of each are listed below.

DANGER

DANGER: To warn of immediate hazards which will result in severe personal injury or death.

WARNING

WARNING: To warn of hazards or unsafe practices which could result in severe personal injury or death.

CAUTION

CAUTION: To warn of hazards or unsafe practices which could result in minor personal injury.

ATTENTION!

ATTENTION! To warn of practices which could result in extensive equipment damage.

NOTE

NOTE: To direct your attention to important equipment information or special instructions for preventing damage to equipment.

Symbols at the top of the list are the strongest warnings. However, all symbols represent important information which should be observed to protect you and others from harm and injury, and to prevent damage to equipment.

SAFETY DECALS

Decals directly attached to various parts of the sweeper are highly visible safety reminders which should be read and observed. Make sure the decals are replaced if they become illegible or damaged. The decal below is located in the drive compartment. Other decals on your machine appear on the next page.



CAUTION

For Your Safety And Safety Of Others:

1. **DO NOT Operate Machine:**
Unless Operation Manual Is Read And Understood
Unless Authorized And Trained.
In Areas With Flammable Or Explosive Conditions.
Without Adequate Ventilation.
2. Do Not Use Flammable Cleaning Materials.
3. Inspect Vehicle For Fuel Leakage.
4. Drive Slowly On Inclines And Slippery Surfaces.
5. Do Not Power Dump Hopper Unless Vehicle Is On A Level Surface.
6. Before Leaving Vehicle: Lock Parking Brake, Stop Engine, And Remove Key.

Located at the impeller.



Located at the impeller.

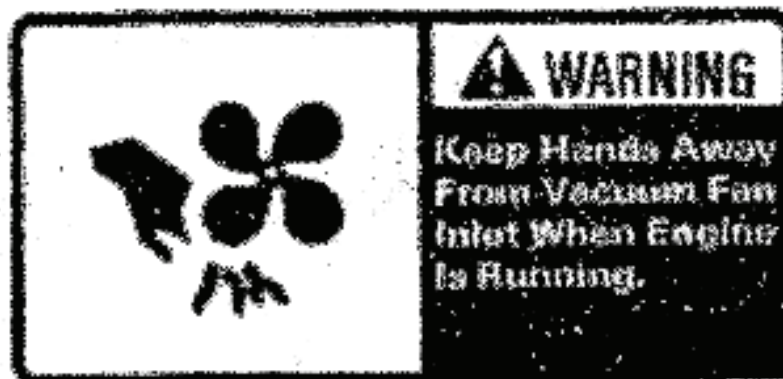

Located on the high dump and low dump hopper.



Located on the high dump hopper.

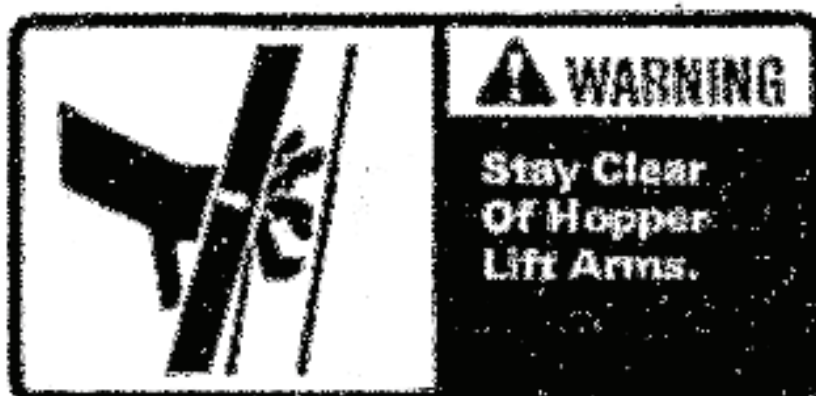

Located on the shroud of the radiator.



BASIC POWERBOSS™ SAFETY

PowerBoss™ sweepers should never be operated unless: 1. the operator is trained and authorized to operate the equipment and, 2. the equipment is free of malfunctions. Malfunctioning equipment should be removed from service.

DANGER

1. Keep cigarettes, matches, and all other flame sources away from the sweeper. Gasoline, LP gas, and diesel fuel are highly flammable. Lead acid batteries are equally dangerous due to the highly explosive hydrogen gas they emit.

WARNING

1. Before starting the engine, make sure that:
 - You are securely seated in the operator's seat.
 - The parking brake is locked.
 - The directional control pedal is in neutral.
 - The throttle is in idle.
 - Hydraulic controls are in OFF position.
2. During operation:
 - Keep your hands and body clear of moving parts, especially when the hopper or lift arms are partially or fully raised.
 - Make sure others in the area stay clear of the equipment and moving parts.
 - Never attempt to dump debris from a dock or mezzanine. Dump from ground level only.
3. When leaving the sweeper unattended:
 - Place the controls in OFF position.
 - Set the parking brake.
 - Shut off the engine.

4. During cleaning and maintenance:
 - Always stop the engine and set the parking brake before servicing.
 - Never use detergents or cleaners that are flammable or combustible.
 - Never inflate a pneumatic tire without using a safety cage.
 - Do not attempt any impeller adjustment unless you have shut off the engine. Never place your hands near the intake hoses or inlet when the engine is running.
 - When high dumps materials, always engage the safety arm before getting under the hopper. Do not rely on the hydraulic cylinder to keep the hopper raised.

5. When servicing or repairing the fuel system:
 - Work in a properly ventilated area, do not smoke, or allow an open flame near the fuel system.
 - Never bypass safety components unless you are testing them.
 - Never bypass the fuel filter lock or oil pressure switch, except when testing them (and always reconnect them after testing).
 - Wear gloves to disconnect the tank coupling.

6. Do not operate an LPG powered sweeper when any component in the fuel system is malfunctioning or leaking.

7. Replace any defective safety components before operating the sweeper.

 **CAUTION**

1. Do not drive with the hopper in the raised position except the few feet necessary to position the hopper over the dumpster or receptacle. Driving with the hopper raised reduces visibility and creates conditions for striking overhead objects, throwing the machine off balance, and other hazards.

2. Travel slowly on grades.

3. Place a block or chock behind the wheels when parking on inclines.
4. Use special care when traveling on wet surfaces.
5. Observe all proper procedures for operation and maintenance of the sweeper, as outlined in this manual.
6. Remain alert at all times to people and equipment in and around your area of operation.

ATTENTION!

1. Do not operate the #2 PFR lever before the #1 light illuminates.
2. Never push or tow a machine faster than specified.

TABLE OF CONTENTS
Specifications

SW 88.....	C-1
SW 78.....	C-3

SPECIFICATIONS 8W 88

FRAME, WEIGHT, DIMENSIONS

Frame	Unitized construction, 3/16" steel plate, reinforced at stress points
Net Weight	2200 lb.
Shipping Weight	3250 lb.
Length	109.58"
Width	60.12"
Height	57.0"
Height with Overhead Guard	67.0"
Height with Cab	68.50"

ENGINE, BATTERY

Battery	Electric start 12 volt, maintenance free
Gasoline and LPG Engine	Liquid cooled, transverse mid-engine design 48 HP, develops 58 HP at governed 2400 RPM
Diesel Engine	Liquid cooled, transverse mid-engine design 48 HP, develops 58 HP at governed 2400 RPM

STEERING, BRAKES, PERFORMANCE

Steering	Drive and steering through rear wheel
Parking Brakes	Mechanical drum brakes on two front wheels
Max. Forward Speed	10 mph
Min. aisle Width Required for U-Turn	11.4"

FLUID CAPACITIES

Fuel Tank	8 gal.
Radiator	3 qt.
Total Coolant System	6 qt.
Hydraulic Fluid Reservoir	8 gal.

CLEANING COVERAGE, TANK AND HOPPER CAPACITIES

Vacuum System	High speed 9" impeller Two fully enclosed, positive sealed panel filters 120 sq. ft. of filtering area Two electric filter shakers
Total Sweep Path	60"
Main Broom Path	42"
Sweep Coverage	178,000 sq. ft. per hour with 6" overlap (based on 60" path at 7.5 mph)
Hopper Capacity	1,200 lb., 16 cu. ft.

CLEANING COMPONENTS

Main Broom	Cylindrical, one-piece, disposable, 14" diameter x 42" long
Side Broom	Rotary, one-piece, disposable, 26" diameter

HYDRAULICS

Wheel Motor	Char-Lynn 4000 Series 15 cu. in. per rev. displacement High torque, low speed Protected by 4000 psi relief valves
Broom Motors	Char-Lynn H Series Gearotor, high torque, low speed
Propulsion Pump	Cesana Variable Displacement Piston Pump 1.24 cu. in. per rev. displacement Protected by 4000 psi relief valves
Accessories Pump	Cesana gear pump .84 cu. in. per rev. displacement Protected by 2200 psi relief valve
Directional Control Valve	Cesana
System Filter	Donaldson 10 micron spin-on with filter condition indicator
Heat Exchanger	One-piece tubular coil

SPECIFICATIONS SW 78

FRAME, WEIGHT, DIMENSIONS

Frame	Utilized construction, 3/16" steel plate, reinforced at stress points
Net Weight	2700 lb.
Shipping Weight	3100 lb.
Length	103.56"
Width	54.12"
Height	57.0"
Height with Overhead Guard	67.0"
Height with Cab	83.50"

ENGINE, BATTERY

Battery	Electric start 12 volt, maintenance free
Gasoline and LPG Engine	Liquid cooled, transverse mini-engine design 38 HP, develops 29 HP at governed 2400 RPM

STEERING, BRAKES, PERFORMANCE

Steering	Drive and steering through rear wheel
Parking Brakes	Mechanical drum brakes on two front wheels
Max. Forward Speed	8 mph
Min. Isle Width Required for U-Turn	108"

FLUID CAPACITIES

Fuel Tank	8 gal.
Radiator	3 qt.
Total Coolant System	6 qt.
Hydraulic Fluid Reservoir	6 gal.

CLEANING COVERAGE, TANK AND HOPPER CAPACITIES

Vacuum System	High speed 9" impeller Two fully enclosed positive sealed panel filters 100 sq. ft. of filtering area Two electric filter shakers
Total Sweep Path	54"
Main Broom Path	36"
Sweep Coverage	158,400 sq. ft. per hour with 6" overlap (based on 54" path at 7.6 mph with 6" overlap)
Hopper Capacity	1,000 lb., 14 cu. ft.

CLEANING COMPONENTS

Main Broom	Cylindrical, one-piece, disposable, 14" diameter x 36" long
Side Broom	Rotary, one-piece, disposable, 28" diameter

HYDRAULICS

Wheel Motor	Char-Lynn 2000 Series 18.7 cu. in. per rev. displacement High torque, low speed Protected by 3000 psi relief valves
Broom Motors	Char-Lynn H Series Gerotor, high torque, low speed
Propulsion Pump	Cessna Variable Displacement Piston Pump 1.24 cu. in. per rev. displacement Protected by 3000 psi relief valve
Accessories Pump	Cessna gear pump .86 cu. in. per rev. displacement Protected by 1500 psi relief valve
Directional Control Valve	Cessna
System Filter	Donaldson 10 micron spin-on with filter condition indicator
Heat Exchanger	One-piece tubular coil

TABLE OF CONTENTS
Component Descriptions

The Engine.....	D-1
The Air Intake System.....	D-1
The Electrical System.....	D-2
The Fuel System.....	D-3
The Coolant System.....	D-3
The Lubrication System.....	D-4
The Hydraulics Systems.....	D-4
The Vacuum System.....	D-5
Sweep Components.....	D-5
Hoppers.....	D-6
Steering, Brakes, and Tires.....	D-6

THE ENGINE

Engines are:

- 4-cylinder,
- liquid cooled,
- electrically started, and
- inverter, mid-engine designed.

Standard gasoline engines for 66 series are 49 HP. They develop 38 HP at governed 2400 RPM.

Standard gasoline engines for 79 series are 28 HP. They develop 29 HP at governed 2400 RPM.

Standard diesel engines are 46 HP. They develop 48 HP at governed 2400 RPM.

Additional information

For additional detailed information about the engine on your sweeper, refer to the vendor's engine manual furnished with this manual. In it you will find information on the following components:

- carburetor
- alternator
- governor
- fuel pump
- starter
- points and plugs
- fan belt
- water pump
- distributor

THE AIR INTAKE SYSTEM

Air Intake System

Engines are equipped with a dry cartridge type air filter with a rubber dust cup in the housing. The filters are accessible for easy removal and cleaning.

All engines have two-stage Donaldson filters.

THE ELECTRICAL SYSTEM

Battery The battery is a 12-volt, 325 cold cranking amp, maintenance free battery.

Fuses The fuses which protect the circuit are located in four fuse holders on the instrument control panel. Below is a chart showing left-to-right location of fuses and their purpose.

Fuses

As viewed left to right from the operator's seat:

30 AMP -	Main Fuse
20 AMP -	Filter Shaker Motors, Horn, Fuel Gauge, Option Connector
15 AMP -	Oil Pressure Gauge, Water Temperature Gauge, Hour Meter
15 AMP -	Headlights, Taillights, Gauge Lights

Instruments Gauges and indicator lights include an ammeter, hour meter, fuel gauge, oil pressure gauge, and water temperature indicator. For descriptions of these basic instruments and various accessory instruments, refer to the controls section of this manual.

THE FUEL SYSTEM

Engines receive fuel from an 8-gallon capacity tank. Fuel is received through inline, disposable filters. Fuel supply is monitored by a fuel gauge. Fuel system characteristics of gasoline, LPG, and diesel engines are listed below.

Gasoline

Major fuel system components for gasoline-fueled engines are:

- fuel tank
- fuel filter
- mechanical fuel pump
- carburetor
- manually operated carburetor choke

Liquid Propane Gas (LPG)

Major fuel system components for LPG-fueled engines are:

- fuel tank
- pressure relief valve/fuel filter
- electric lock off valve
- combination water heated vaporizer and primary regulator
- combination carburetor and secondary regulator

Diesel

Major fuel system components for diesel-fueled engines are:

- fuel tank
- fuel water trap
- fuel filter
- fuel lift pump
- fuel injection pump
- fuel injectors

THE COOLANT SYSTEM

Engine coolant is stored in a three quart capacity radiator and circulates through hoses and engine block which bring the total system capacity to six quarts.

A spring-loaded valve in the radiator pressure cap, designed to open at 14 psi, closes the outlet to the overflow pipe.

THE LUBRICATION SYSTEM

Grease fittings supply lubrication to:

- Impeller bearing housing
- steering gear box
- steering link arm
- steering link assembly
- pillow blocks supporting dump arms

For detailed information on lubrication requirements and the lubrication points and grease fittings, refer to the Maintenance section of this manual.

THE HYDRAULIC SYSTEM

Hydraulic fluid is pumped from an eight-gallon capacity reservoir. The fluid passes through a 100 mesh suction strainer into supply lines which circulate fluid through two systems: the propulsion system and the accessory system. Fluid returns through a heat exchanger and a filter equipped with a condition gauge.

Propelling System

The major component of the propelling system is a variable displacement piston pump protected by relief valves. The pump sends fluid to drive the wheel motor which controls the forward and reverse speed of the machine, as well as dynamic braking.

Accessories System

The major component of the accessories system is a gear pump. The gear pump, protected by a relief valve, sends fluid through a control valve to raise and lower hopper, to rotate hopper (on high dump models), and to drive brooms, brushes, and other accessories.

Brooms are driven by gearotor-type high torque, low speed motors. Hopper is raised, lowered, and rotated (on multi-level high dump) by hydraulic cylinders.

THE VACUUM SYSTEM

Impeller and Belts

The vacuum system operates from three basic components:

- a high speed 9" impeller, belt-driven off the engine
- 2 gripitch belts

Filters and Shakers

SW models have two fully enclosed, positive sealed, quick-change filters providing 100 sq. ft. of filtering area and two electric shakers for clearing the filters.

SWEEP COMPONENTS

Main Broom

The main broom has the following features:

- one-piece, cylindrical, and disposable
- runs at constant RPM
- can be changed in less than five minutes
- is raised and lowered from operator compartment
- floats for uneven surfaces
- adjusts for pressure and wear

Side Broom

A rotary one-piece disposable side broom on SW models can be quick changed in seconds without tools, is bumper protected, and adjustable for angle, pressure, and wear.

Skirts

Skirts on the bottom of main broom door and at the back of the broom chamber help contain the dust inside the sweeping and vacuuming compartment.

Capabilities

Sweep paths and coverages are listed by model in the Specifications section of this manual.

HOPPERS

SW

SW hoppers are constructed of 12 GA steel and come with either powered floor level dump or multi-level high dump.

All machines are equipped with a frame seal and side seals to contain dust and fine debris within the hopper.

Rotary Trash Relocator

The rotary trash relocator (RTR) on high dump models increases the debris-holding capacity of the hopper, extending the sweeping time before dumping. By rotating the hopper about halfway through the dump rotation, the debris at the lip of the hopper moves to the front wall, leaving the entrance area clear to receive and hold more debris.

STEERING, BRAKES, AND TIRES

Steering

PowerBoss™ sweepers are designed with standard cam and lever steering through the rear wheel.

Brakes

PowerBoss™ sweepers are equipped with a parking brake, mechanically operated by a cable which connects to drum brakes on the two front wheels.

Tires

PowerBoss™ sweepers use an interchangeable, two-piece, bolt-together cast rim for mounting solid tires. For more detailed information related to dimensions and pressure requirements, refer to the Specifications and Maintenance sections of this manual.

TABLE OF CONTENTS
Operation

Basic Operating Controls.....	E-1
Sweeping Controls.....	E-5
Debris Hopper Dump Controls.....	E-6
Operating Procedures.....	E-7
Pre-Operation Checks.....	E-7
Starting.....	E-7
Slowing and Stopping.....	E-7
Operating on Grades.....	E-10
Sweeping.....	E-10
Emptying the Hopper.....	E-10
Using the Rotary Trash Relocator.....	E-12
Transporting the Machine.....	E-13
Using the Accessories.....	E-13

Basic Operating Controls

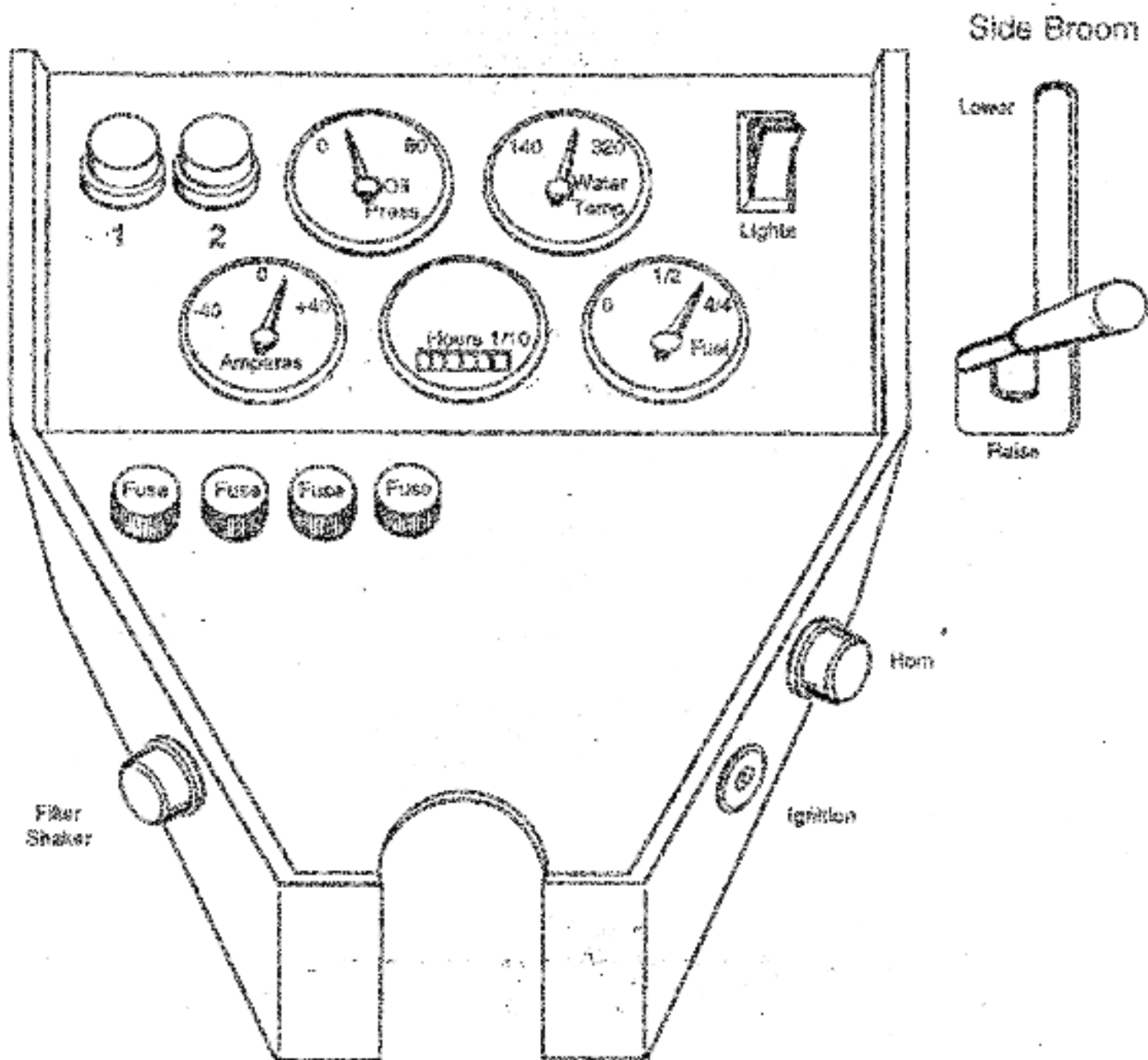

ENGINE COOLANT TEMPERATURE GAUGE

The engine coolant temperature gauge registers the temperature of engine coolant. Temperatures above 210° F indicate an overheating engine.

THROTTLE

The throttle adjusts the engine speed from idle to the operating speed.

- The throttle should be in the IDLE position when starting the engine and immediately before shutdown.
- Full throttle position should be used during operation to insure proper broom speed and dust control.

DIRECTIONAL CONTROL PEDAL

The directional control pedal controls the speed and direction of the machine. It is also used for slowing the machine or stopping.

- To propel the machine forward, apply pressure to the front of the pedal, increasing pressure to increase speed.
- To propel the machine backward, apply pressure to the rear of the pedal.
- To slow or stop the machine, move foot pedal into neutral.
- For quick stops or emergency stops move foot pedal past neutral into opposite position.

The sweeper is equipped with a speed limiter, a stop under the pedal which can be raised to reduce maximum speed.

PARKING BRAKE

The mechanical drum brakes on the two front wheels are used primarily for parking the machine and are operated by the brake pedal. Check wheels if machine is parked on an incline.

NOTE: The directional control pedal is used to slow and stop during normal operation.

- To engage the brakes, press down on the pedal.
- To lock the brakes, tilt the pedal forward.
- To release the brakes, apply pressure to the back of the pedal and release.

Sweeping Controls

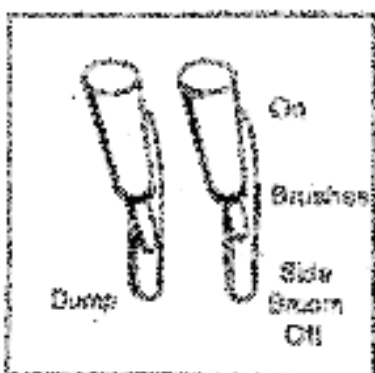

Low Dump
Model

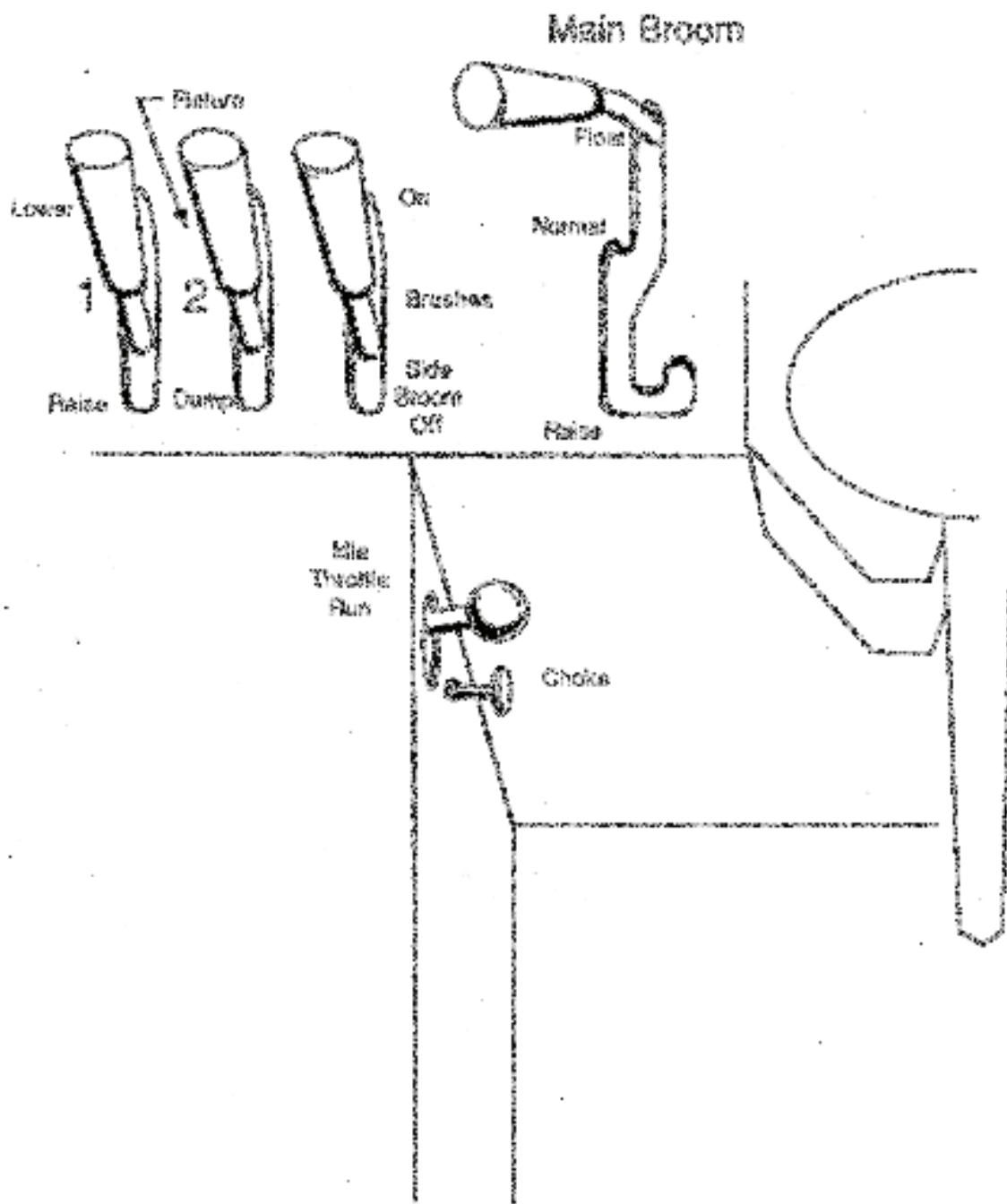

SWEEPING CONTROLS

BROOM CONTROL LEVER

The broom and brush control lever to the left of the main broom handle activates the brooms.

NOTE: Even though brooms are rotating each can be lowered independently.

When sweeping:

- To activate the main and side brooms, push this lever to the ON position.
- To activate the main broom only, pull this lever to the SIDE BROOM OFF position.
- The center (straight up) position is the OFF position.

MAIN BROOM HANDLE

The main broom handle to the immediate left of the instrument panel raises and lowers the main broom.

- For normal sweeping, position the handle at NORMAL on the handle slot.
- For extremely uneven floors, position the handle at FLOAT on the handle slot.

NOTE: Extensive use of the float position reduces broom life.

- When not sweeping, position and lock the handle at RAISE on the handle slot.

SIDE BROOM HANDLE

The side broom handle to the right of the instrument panel raises and lowers the side broom.

- When not sweeping, the side broom should remain in the raised position.
- To lower the broom, position the handle at LOWER in the handle slot.
- To raise the broom, position the handle at RAISE in the handle slot.

DEBRIS HOPPER DUMP CONTROLS

HOPPER FILTER SHAKER BUTTON

This button is used to activate the filter shakers prior to dumping or as needed for cleaning the dust control filters. Hold the button in approximately 15 - 20 seconds, or as long as necessary to clean the filters.

MANUAL LIFT OUT MODELS

Two handles on top of the hopper are used to manually lift the hopper off the support brackets which attach it to the frame.

LOW DUMP MODELS

The left lever on the front control panel is used to raise and dump the hopper.

- To raise the hopper to dump position, pull back the lever marked DUMP from its center off position until the hopper raises to dump position.
- To lower the hopper after dumping, return the lever to its center off position.

 **CAUTION:** Do not leave the hopper in RAISE position for an extended period of time.

HIGH DUMP MODELS

The two far left levers on the front control panel are used to raise the hopper to any height up to 60" and dump it.

NOTE: Levers are spring loaded to a center off position.

- To raise the hopper, pull back Lever 1 to the RAISE position and hold until the hopper raises to the proper height for the dumpster or container.
- To empty debris, pull back Lever 2 to the DUMP position to rotate the hopper forward and empty the debris.
- To rotate the hopper back, push Lever 2 forward to the RETURN position until the hopper rotates and stops.
- To lower the hopper, push Lever 1 forward to the LOWER position, until the hopper stops.

ROTARY TRASH RELOCATOR (RTR)

Rotary Trash Relocator (RTR) is a standard feature on high-dump models. Its purpose is to increase the holding capacity of the debris hopper to make dumping the hopper necessary less frequently.

OPERATING PROCEDURES*

PRE-OPERATION CHECKS

Prior to starting the engine, check the following:

1. Engine oil level
2. Engine coolant level
3. Fuel level
4. Hydraulic fluid level
5. Brakes, steering, and directional controls
6. The floor beneath the machine for leak spots

Fluid levels should be correct. Brakes, steering, and directional controls should be functioning properly. Hoses, lines, and tanks should be free of damage and leaks.

STARTING

 **WARNING:** Before cranking the engine, seat yourself in the operator's seat and make sure the parking brake is locked.

1. Make sure the directional control pedal is in neutral position.
2. Make sure the throttle is in idle position.
3. **Gasoline-Powered:** Turn the key to START position, then release. If the engine is cold, pull out the choke knob, turn the key to START, then release. When the engine is running smoothly, push in the choke knob.

Diesel-Powered: Be sure engine stop knob is pushed in. Turn the key to START position and wait 15 - 20 seconds. Then turn the key to START POSITION and release.

NOTE for both gasoline and diesel-powered engines: If the engine fails to start, do not continue cranking for over ten seconds. Allow the starter motor to cool between attempts.

4. Allow the engine to warm up approximately two minutes.
5. Move the throttle from IDLE to RUN.
6. Unlock the parking brake.
7. Move the machine forward or backward as follows:
 - Forward: Apply pressure to the front of the directional control pedal, increasing pressure to increase speed.
 - Reverse: Apply pressure to the rear of the pedal, increasing pressure to increase speed.

SLOWING AND STOPPING

1. Allow the directional control pedal to move into neutral. The machine will slow and coast to a stop.

* Refer to the control drawings on the following pages.

Basic Operating Controls

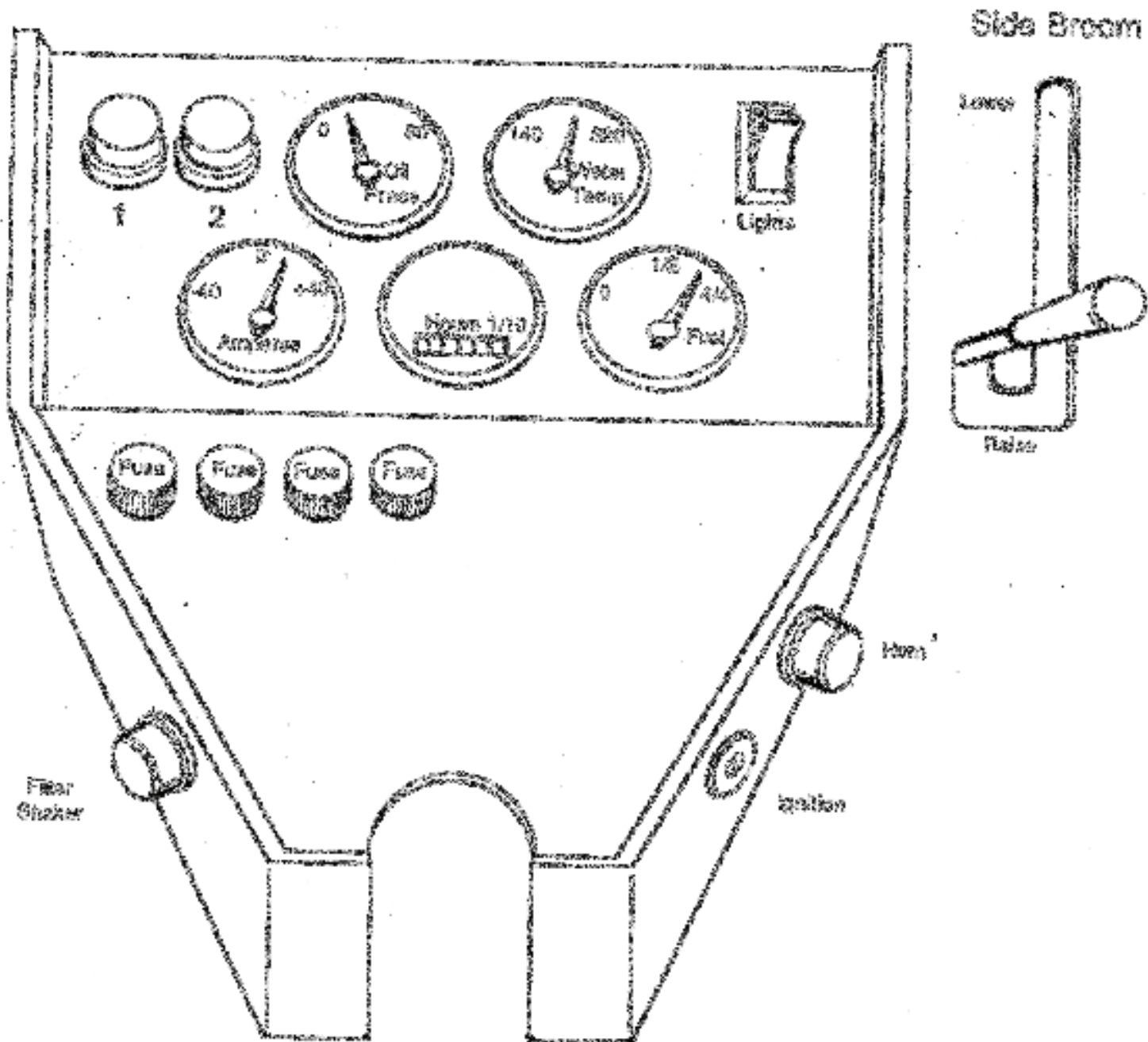

Sweeping Controls

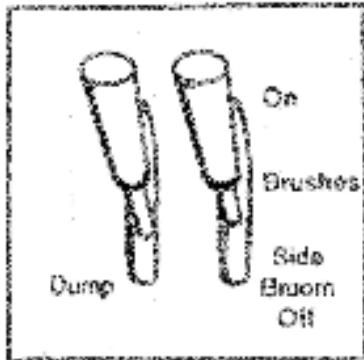

Low Dump Model

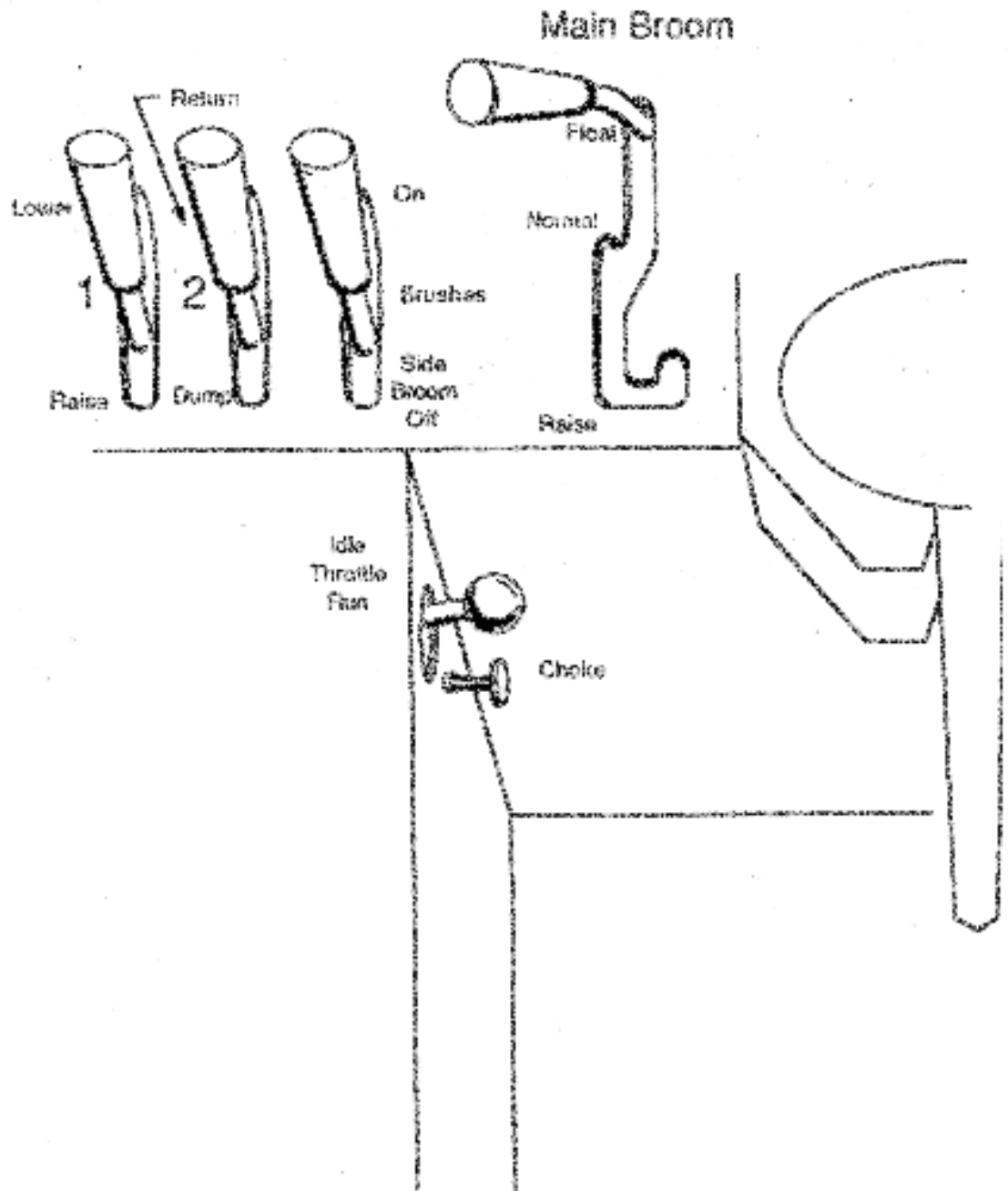

OPERATING ON GRADES

1. Always travel slowly.
2. Exercise extreme caution when traveling across or turning on grades.

SWEEPING

1. Lower the brooms.
 - Lower the main broom by positioning the main broom handle at NORMAL on the handle slot.
 - When sweeping extremely uneven floors, position the main broom handle at FLAT on the handle slot.
 - Lower the side broom by positioning the side broom handle at LOWER in the handle slot.
2. Activate the broom motors.
 - Activate the main broom motor by pulling the broom and brush control lever to the SIDE BROOM OFF position.
 - Activate both main and side broom motors by pushing the broom and brush control lever to the ON position.
3. Drive the machine over the area to be swept.

EMPTYING THE HOPPER

Manual Lift-Out Models

1. Grasp the handles on top of the hopper.
2. Lift the hopper straight up (about 8") until the support brackets clear the frame.
3. Move the hopper back and dump it out.

NOTE: If the debris in the hopper is too heavy, the hopper can be rotated and partially dumped to make it lighter.

Low Dump Models

1. Drive the machine in the dumping area.

NOTE: Broom control lever must be in center off position.

 **WARNING:** Never attempt to dump debris off a dock or overhang. Dump it onto ground surface only.

2. Push the throttle to the IDLE position.
3. Pull back the lever marked DUMP from its center off position until the hopper raises and locks in dump position. Debris will empty onto floor.
4. With the hopper in the raised position, press the filter shaker button for 10 to 30 seconds to shake the dust from the hopper filter(s).

6. Use the directional control pedal to slowly back the machine a distance of about five feet.

⚠ WARNING: It is unsafe to travel an extended distance with the hopper raised. Travel only the distance necessary to clear the debris area.

⚠ WARNING: Never place your hands or other body parts under a raised or partially raised hopper unless the safety arm is in place.

7. Use the directional control pedal to stop the machine, then release the DUMP lever to return it to its center off position.
8. Pull the throttle back to FAST and resume sweeping.

High Dump Models

1. Drive the machine to the dumping area.
2. Use the directional control pedal to position the machine so that the space between the machine and the container or dumpster is adequate to raise the hopper.

NOTE: Speed control lever must be in center off position.

3. Reduce the engine speed.
4. Pull back Lever 1 to RAISE position and hold until the bottom of the hopper is high enough to clear the top of the container.

⚠ WARNING: Never place your hands or other body parts near the lift arms when the hopper is operating.

5. Use the directional control pedal to slowly and carefully move the machine forward until the hopper is properly positioned to dump debris into the container.

⚠ CAUTION: It is unsafe to travel an extended distance with the hopper raised. Travel only the distance necessary to position the hopper.

6. At this point, shake fibers for 20 - 30 seconds. Pull back Lever 2 to DUMP position to rotate the hopper forward and empty the debris.
7. After hopper empties, push Lever 2 forward to RETURN position until the hopper rotates and stops.
8. Slowly back machine away from dumpster approximately 5 ft.
9. Push Lever 1 forward to the LOWER position until the hopper drops.

**USING THE ROTARY
TRASH RELOCATOR
(RTD)**

1. Use the directional control pedal to stop the machine on a level surface.
2. Move the throttle to IDLE position.

NOTE: As you complete Steps three and four, observe the two red lights labeled 1 and 2 in the upper left corner of the control panel.

- Light 1 Illuminates when the hopper reaches the minimum height required to use the RTD feature.
 - Light 2 Illuminates when the hopper reaches the rotation stop point.
3. Pull back Lever 1 to the RAISE position and hold until Light 1 Illuminates, then release.

 **WARNING:** Make sure no one is in the area under or around the hopper.

4. Pull back Lever 2 to DUMP position and hold until Light 2 Illuminates, then release.

NOTE: This rotates the hopper, causing debris to move from the rear entrance to the front wall of the hopper. Rotating beyond this point will cause debris to be dumped from the hopper.

5. Push Lever 2 forward to RETURN position until the hopper rotates back and stops.
6. Push Lever 1 forward to the LOWER position until the hopper returns to the normal operating position.
7. Move the throttle back to RUN and resume sweeping.

TRANSPORTING THE MACHINE

Loading

1. Position the machine on the transport vehicle or trailer and apply the parking brake.
2. Tie the machine down using the tie down holes in the frame behind both front wheels and eye bolts located at rear of frame.

NOTE: Attach the tie downs to the frame only.

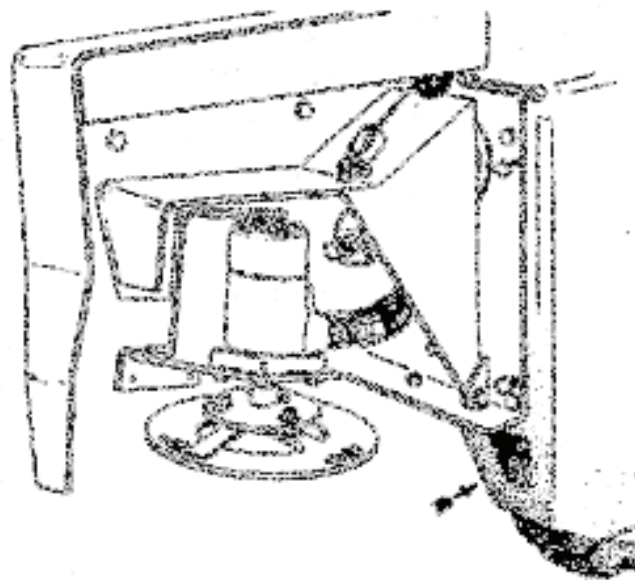

Pushing

1. Push the machine from the front or rear using bumpers only.

ATTENTION! Do not tow or push the machine a distance of more than .5 miles or faster than one mile per hour. Exceeding these restrictions may cause damage to the hydraulic system. If towing will exceed the above restrictions, the rear wheel must be raised or supported by a dolly.

USING THE ACCESSORIES

Accessory switches are labeled as listed below. Locations are indicated in parenthesis.

Safety Lights
(Top rear of machine or bottom side of overhead guard)

The hazard lamp comes on and goes off with the ignition switch.

Cab Heaters (Front wall of the driver compartment)	To receive warm air from the heater assembly, open the heater valve in the engine compartment, then turn the blower switch to the desired speed setting.
Blower (Under the top cover to the operator's left)	The blower blows debris from hard-to-reach areas into the path of the sweeper. To activate the blower, flip the lever on the impeller assembly where the hose attaches.
Cab Fan (Upper left corner of cab on base of fan)	To activate the fan, flip the switch toggle.
Lights (Upper right corner of instrument panel)	To use headlights, taillights, and the brush spot light (when equipped), flip the rocker switch.
Windshield Wipers (Driver's Console)	To use the windshield wipers, turn the switch on.
Cab Pressurizer Control (On top of console to driver's left)	Cab pressurizer is controlled using the three-speed switch.
Fire In Hopper Indicator (Top front of console to driver's left)	The fire in hopper lamp lights when temperature in the hopper reaches 135°. This is an unsafe condition which demands immediate attention.
Clogged Filter Indicator (Top front of console to driver's left)	The clogged filter lamp lights when dust filters become clogged and excessively restrict vacuum air flow.

TABLE OF CONTENTS

Maintenance

Introduction.....	F-1
Preventive Maintenance Chart.....	F-2
Engine.....	F-3
Air Intake and Exhaust Systems.....	F-7
Air Filter Removal.....	F-7
Air Filter Cleaning.....	F-8
Air Filter Inspection.....	F-8
Air Filter Installation.....	F-9
Electrical System.....	F-10
Electrical Schematic.....	F-10
Battery Cleaning.....	F-11
Battery Replacement.....	F-12
Fuse Replacement.....	F-12
Fuel System.....	F-13
Checking the LFD Fuel Filter Lock.....	F-14
Draining the Kubota Water Trap.....	F-14
Replacing the Kubota Fuel Filter Element.....	F-15
Priming the Kubota Fuel System.....	F-15
Cleaning the Perkins Water Trap.....	F-15
Replacing the Perkins Fuel Filter Element.....	F-15
Priming the Perkins Fuel System.....	F-16
Coolant System.....	F-17
Blowing Out Radiator Fins.....	F-17
Reverse Flow Flushing.....	F-17
Lubrication.....	F-19
Changing Engine Oil.....	F-20
Lubrication Points.....	F-21
Lubrication Chart.....	F-22

Hydraulics System	F-25
Filling the Fluid Reservoir.....	F-25
Maintaining Cooling Coil Efficiency.....	F-26
Changing the Hydraulic Fluid.....	F-26
Changing the Hydraulic Fluid Filter.....	F-27
Adjusting the Directional Control Return Spring.....	F-27
Adjusting Machine Speed.....	F-29
Hydraulic Schematic	F-30
SW 78 Multi-Level Dump.....	F-31
SW 78 Low Dump.....	F-32
SW 88 Multi-Level Dump.....	F-33
SW 88 Low Dump.....	F-34
Vacuum System	F-35
Belt Tensioning	F-36
Pulley Realignment	F-38
Lubrication of Impeller Bearing Housings	F-39
Sweep Components	F-40
Broom Door Flap Inspection	F-40
Broom Door Flap Replacement and Adjustment	F-41
Main Broom Adjustment Test	F-41
Main Broom Adjustment	F-42
Main Broom Taper Adjustment	F-43
Side Broom Adjustment Inspection	F-45
Side Broom Height (Wear) Adjustment	F-45
Side Broom Angle Adjustment	F-46
Side Broom Lift Cable Adjustment	F-47
Main Broom Replacement	F-47
Side Broom Replacement	F-49
Hoppers	F-50

Low Dump Hopper Removal and Replacement	F-50
High Dump Hopper Removal and Replacement	F-52
Filter Removal	F-53
Filter Clearing	F-54
Filter Replacement	F-54
Hopper Floor Clearance and Dump Adjustments	F-55
Adjusting Low Dump Maximum Hopper Dump Angle.....	F-56
Hopper Vacuum Gasket Mount Adjustment.....	F-58
Hopper Flap Replacement.....	F-58
Hopper/Frame Seal Replacement.....	F-59
Steering	F-60
Parking Brake	F-61
Parking Brake Adjustment.....	F-61
Tires	F-62
Inflation.....	F-62
Changing Solid Tires.....	F-62
Changing Pneumatic Tires.....	F-62
Miscellaneous Adjustments	F-63

INTRODUCTION

Regular maintenance on your sweeper results in better cleaning, faster cleaning, and a prolonged service life for the equipment and components. This section contains the following information to help you give your sweeper the maintenance attention it requires:

- A Preventive Maintenance Chart
- Service Instructions for Required Maintenance Tasks

Because it is extremely important to your safety, you will see the following WARNING repeated throughout this section:

WARNING

Never attempt to perform any service on the equipment or components until the engine is OFF, the parking brake is LOCKED, and the wheels are CHOCKED.

PREVENTIVE MAINTENANCE CHART

FREQUENCY (IN HOURS)					SERVICE (BY MAINTENANCE AREA)
Daily	50	100	200	300	
			X		<p>ENGINE</p> <p>Pressure wash engine.</p> <p>For additional maintenance requirements, refer to the engine manual furnished with this model.</p>
X					<p>AIR INTAKE AND EXHAUST SYSTEMS</p> <p>Empty rubber dust cup of air filter element.</p> <p>Clean air filter. NOTE: Clean more often in dusty conditions.</p>
	X			X	<p>Replace air filter.</p>
		X			<p>ELECTRICAL SYSTEMS</p> <p>Check electrolyte level in battery cells and fill as needed.</p>
			X		<p>Clean battery top.</p>
X					<p>COOLANT SYSTEM</p> <p>Check coolant level and fill as needed.</p>
	X				<p>Inspect radiator fins and clean as needed.</p>
		X			<p>Blow out radiator fins.</p>
				X	<p>Drain and flush coolant system.</p>

PREVENTIVE MAINTENANCE CHART

FREQUENCY (IN HOURS)					SERVICE (BY MAINTENANCE AREA)
Daily	50	100	200	500	
X					HYDRAULIC FLUID Check hydraulic reservoir gauge and fill as needed. Blow off or pressure wash cooling coil. X Replace breather cap filter element. X Replace hydraulic fluid and filter. Check functioning of directional control pedal and adjust as needed. X Clean hydraulic fluid strainer in reservoir.
		X			
X					
X					SWEEPING COMPONENTS Inspect brooms for wear and remove strings and debris from bristles and drive assembly. Inspect broom skirts for wear and adjust or replace as needed. Rotate main broom end-to-end. Perform main broom adjustment test and adjust as needed. Inspect the side broom for wear and adjust as needed. Replace main and side brooms as needed.
	X				
	X				
	X				
X					

PREVENTIVE MAINTENANCE CHART

FREQUENCY (IN HOURS)					SERVICE (BY MAINTENANCE AREA)
Daily	50	100	200	500	
					HOPPER
X					Check hopper filters and clean or replace as needed.
	X				Check hopper clearance from floor and adjust as needed.
X					Inspect the hopper flaps for wear or damage and replace as needed.
		X			Inspect hopper side and frame seals for wear or damage. Adjust or replace as needed.
				X	Lubricate the pillow blocks supporting the dump mechanism.
					STEERING
				X	Lubricate steering gear box.
				X	Lubricate steering link arm.
				X	Lubricate steering fork assembly.
				X	Check steering gear box for wear and adjust as needed.
			X		PARKING BRAKE
			X		Check for proper functioning and adjust as needed.

PREVENTIVE MAINTENANCE CHART

FREQUENCY (IN HOURS)					SERVICE (BY MAINTENANCE AREA)
Daily	50	100	200	300	
X			X		<p>TRUSS</p> <p>Visually inspect for wear and damage. Repair or replace as needed.</p> <p>Check pneumatic lines for proper air pressure. Adjust inflation as needed.</p>
			X	X	<p>MISCELLANEOUS</p> <p>Inspect rollers and hinges. Tighten and lubricate as needed.</p> <p>Check and clean the splash on rear wall of boom of trailer for damage or excessive wear. Replace as needed.</p> <p>Check area between lid cable, and brake cable for wear.</p>
		X			<p>HOPELLICH</p> <p>Lubricate.</p> <p>Check belt tension and alignment.</p>

ENGINE

Maintenance requirements and service instructions for your sweeper engine are outlined in the following parts of this Maintenance section:

- Air Intake and Exhaust Systems
- Electrical System
- Fuel System
- Coolant System
- Lubrication System

All basic maintenance tasks are listed with their recommended frequencies on the Preventive Maintenance Chart in this manual. Important additional maintenance requirements and instructions are explained in the engine manual which comes with your machine.



WARNING

Never attempt to perform any service on the equipment or components until the engine is OFF, the parking brake is LOCKED, and the wheels are CHOCKED.

AIR INTAKE AND EXHAUST SYSTEMS

To keep the air intake and exhaust systems operating efficiently:

- Empty the rubber dust cup of the air filter element daily.
 - Clean the engine air filter every 50 hours of operation. **NOTE:** Clean more frequently in dusty conditions.
 - Replace the air filter every 500 hours of operation or as required.
-

SERVICE INSTRUCTIONS

WARNING

Never attempt to perform any service on the equipment or components until the engine is OFF, the parking brake is LOCKED, and the wheels are CHOCKED.

AIR FILTER REMOVAL

1. Turn off the engine and set the parking brake.
2. Lift the engine cover.

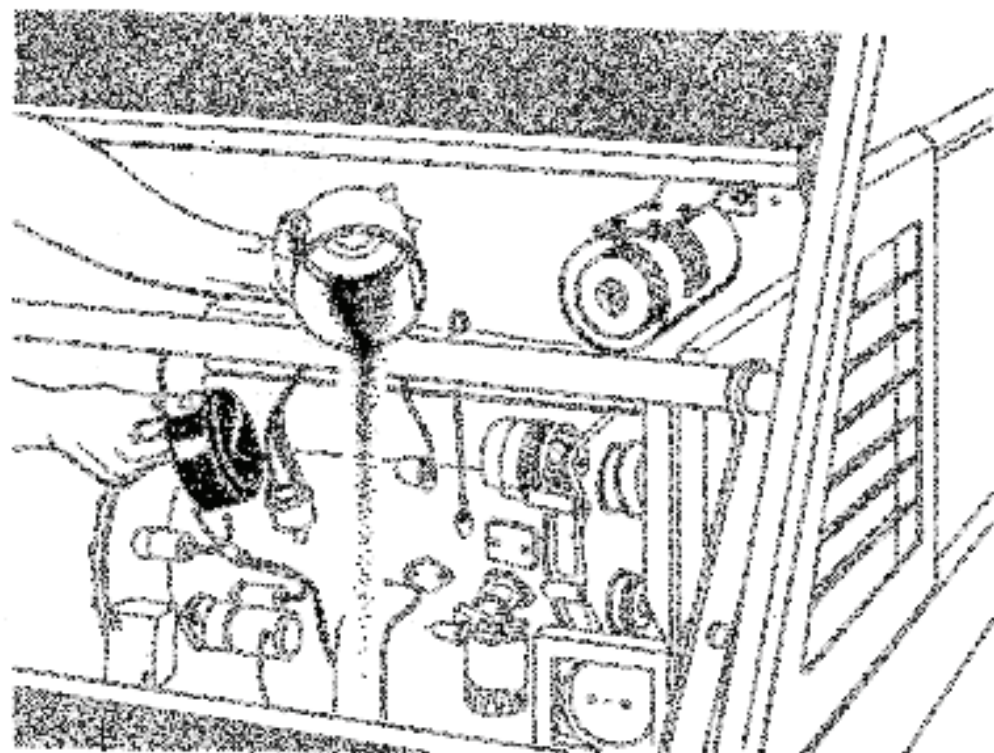

3. Locate the air filter and unscrew the ring clamp.
4. Remove the dust cup.
5. Pull the rubber plug out of the dust cup and empty the contents.
6. Unscrew the wing nut.
7. Put the air filter out of its housing.

AIR FILTER CLEANING

1. Once you have removed the air filter, empty the dust cup and clean the interior of the air filter housing.
2. Use an air hose to blow out the air filter. Air pressure should be 100 psi or less.

AIR FILTER INSPECTION

1. After you clean the air filter, check it for holes by passing a light bulb inside it. If you detect as much as a pin-hole, the filter should be replaced.



AIR FILTER INSTALLATION

1. Wipe out the air cleaner housing with a damp cloth. Be sure all dirt is removed.
2. Install the cleaned or replacement filters so that fins are at the far end of the housing. Be careful not to damage the fins.
3. Replace the wing nut and tighten it.
4. Replace the rubber plug in the dust cap.
5. Replace dust cup being sure embossed word "top" on cup is positioned correctly (up).
6. Tighten the ring clamp.
7. Check condition of intake hoses and clamps.
8. Close the engine cover.

ELECTRICAL SYSTEM

To keep the electrical system in good condition, the following maintenance is required:

- Check the electrolyte level in each of the battery cells every 100 hours of operation and replenish as needed.
 - Clean the battery posts and cover after 200 hours of operation.
 - Use the color-coded wiring harness and the electrical schematic provided in this section to assist you with troubleshooting, testing, and diagnosis.
 - Replace fuses as needed.
-

SERVICE INSTRUCTIONS

WARNING

Never attempt to perform any service on the equipment or components until the engine is OFF, the parking brake is LOCKED, and the wheels are CHOCKED.

BATTERY CLEANING

1. Combine baking soda and water in a strong solution.

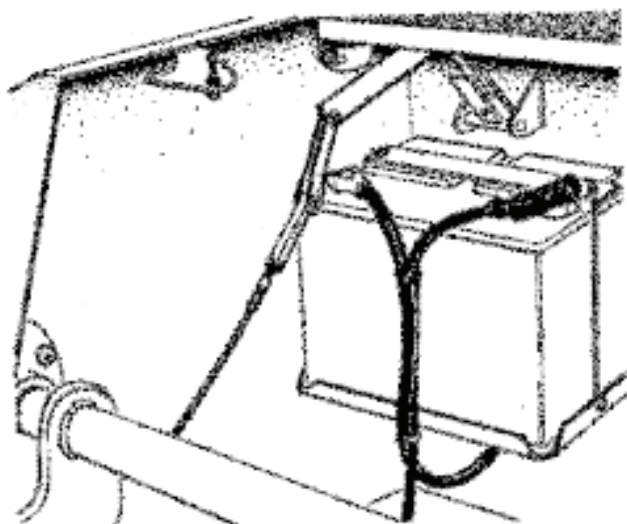

2. Brush the solution over the battery top, including terminals and cable clamps. Make sure the solution does not enter the battery.
3. Using a wire brush, clean the terminal posts and cable clamps.
4. Apply a thin coating of vaseline to the terminals and cable clamps.

BATTERY REPLACEMENT

▲ CAUTION: Remove the negative battery cable before you remove the positive battery cable. This is done to prevent accidental electrical shorting which can result in personal injury.

1. Disconnect the negative (-) cable and then the positive (+) cable.
2. Remove the battery.
3. Install new battery.
4. Connect the positive (+) battery cable first, then the negative (-) cable.

FUSE REPLACEMENT

1. Remove the blown fuse by turning the fuse holder cap counterclockwise.
2. Insert the correct amperage fuse into the fuse holder cap.
3. Install the fuse holder cap by turning the cap clockwise.

NOTE: Remember to reposition the rubber ring under the fuse holder cap.

FUEL SYSTEM

To keep *gasoline engines* in good condition:

- Fill the fuel tank at the end of each day to prevent condensation from forming in the fuel tank. Use clean gasoline of at least 85 octane.
- Replace the fuel filter every 500 hours of use.

NOTE: The PowerBoss™ uses an in-line fuel filter located in front of the fuel pump.

To keep *LPG engines* in good condition:

- Inspect the fuel tanks each time they are refilled. Tanks with broken protecting rings, dents or gauges should be replaced.
- Inspect tank valves for paint, dirt, or other debris in valve openings.
- Check for frosting on or near LPG components. If frosting occurs, locate the suspected leak by applying soapy water to components which may be leaking and watch for bubbles. Repair or replace any defective parts.
- Check the fuel filter lock for proper operation as outlined in the service instructions which follow.

To keep *Kubota diesel engines* in good condition:







- Drain the fuel water trap daily.
- Change the fuel filter element and clean the trap after every 400 hours of operation.
- Prime the fuel system after changing the filter elements, servicing fuel system components, or running out of fuel.

To keep *Perkins diesel engines* in good condition:

- Clean the water trap after every 100 hours of operation.
- Replace the fuel filter element after each 400 hours of operation.
- Prime the fuel system after changing the filter elements, servicing fuel system components, or running out of fuel.

For additional information on the carburetor and fuel pump, refer to the engine service manual furnished with this manual.

SERVICE INSTRUCTIONS

-  **WARNING:** Never attempt to perform any service on the equipment or components until the engine is OFF, the parking brake is LOCKED, and the wheels are CHOCKED.
-  **WARNING:** Never operate an LPG powered sweeper when any component in the fuel system is malfunctioning or leaking.
-  **WARNING:** Never bypass safety components unless you are testing them.
-  **WARNING:** Replace any defective safety components before operating the sweeper.
-  **WARNING:** During repair or servicing of the fuel system, work in a properly ventilated area and do not smoke or allow an open flame near the fuel system.
-  **WARNING:** When disconnecting the tank coupling, always wear gloves. LPG fuel can freeze bare hands.
-  **WARNING:** Under no circumstances should the fuel filter lock or the oil pressure switch be bypassed, except when testing them. After testing, always reconnect them. Bypassing the fuel filter lock or the oil pressure switch after testing creates a potential fire hazard.

CHECKING THE LPG FUEL FILTER LOCK

1. Start the engine. Then remove the wire going to the solenoid section of the fuel filter lock. The solenoid should close, shutting off the fuel supply and stopping the engine.
 - If the engine continues to operate, the fuel filter lock should be replaced.
 - If the engine stops, the fuel filter lock is operating properly.
2. With the engine stopped, let the machine stand while the LPG tank valve is open and the wire is removed from the fuel filter lock. After 10 minutes, try the starter motor.
 - If the engine starts or fires, this indicates a fuel leak has occurred. Replace the fuel filter lock immediately.
 - If the engine simply turns over, this indicates the fuel filter lock is operating correctly.

DRAINING THE KUBOTA WATER TRAP

1. Loosen the knob on the bottom of the trap unit.
2. Wait for the water to drain and watch for the diesel fuel which will follow it.
3. When the diesel fuel begins to drain, tighten the drain knob.

REPLACING THE KUBOTA FUEL FILTER ELEMENT

1. Open the top and side engine access doors.
2. Loosen the vent plug and open the water trap to drain the fuel.
3. Remove the filter element and the trap from the filter head.
4. Remove the water trap bowl from the element and clean it.
5. Lubricate the O-ring and spin the bowl onto a new filter element.
6. Lubricate the O-ring and spin the new filter element, with the clean bowl, onto the filter head.
7. Bleed the fuel lines as explained under Priming the Kubota Fuel System.

PRIMING THE KUBOTA FUEL SYSTEM

1. Fill the fuel tank.
2. Open the top and side engine access doors.
3. Open the air vent at the top of the fuel injection pump.
4. Start the engine, operate it for one minute, then stop it. Or, operate the starter motor every ten seconds until a stream of fuel begins to flow from the vent.

CLEANING THE PERKINS WATER TRAP

1. Lift the engine hood.
2. Clean the outside of the water trap thoroughly.
3. Remove the retaining bolt from the center of the water trap head.
4. Remove the bowl and clean it in cleaning fluid.

NOTE: Do not use gasoline to clean the bowl.

5. Refill the bowl with clean fuel.
6. Position and hold the water trap bowl under the trap head and secure it with the retaining bolt.
7. Bleed the fuel system as outlined under Priming the Perkins Diesel Fuel System.

REPLACING THE PERKINS FUEL FILTER ELEMENT

NOTE: The Perkins diesel fuel filter element is replaced using the same procedures as outlined under replacing the Kubota Fuel Filter Element.

PRIMING THE PERKINS FUEL SYSTEM

1. Locate the fuel pipe on top of the fuel filter cover and unscrew it two or three turns.

NOTE: Do not confuse this pipe with the fuel return pipe to the tank.

2. Locate the hydraulic head locking screw. (It is on the side of the fuel injection pump body.)
3. Loosen the fuel injection pump air vent screws on the governor housing.
4. Use the lever of the fuel lift pump to prime the fuel system.

NOTE: If you are unable to operate the priming lever, turn the engine a complete revolution until fuel bleeds from the vent points free of air bubbles.

5. Tighten connections as follows: first the filter cover fuel pipe, then the fuel injection pump head locking screw, then the governor air vent screws.
6. Loosen the pipe union nut at the inlet of the fuel injection pump.
7. Use the lever on the lift pump to prime the system.
8. When fuel without air bubbles bleeds around the threads, retighten the pipe union.

NOTE: Hand priming may take four or five minutes, but the entire process should be completed with care. Otherwise, the engine may fail to start.

9. Loosen the unions located at the injector ends of the high pressure fuel pipes.
10. Put the accelerator in the full-open position. Make sure the stop control is in the RUN position.
11. Use the starter motor to rotate the engine until fuel oil without air bubbles flows from the fuel pipes. This may require up to 60 seconds of rotation, depending upon rotation speed and the effectiveness of the bleeding operation just outlined.
12. Secure the unions on the fuel pipe and start the engine.

NOTE: If the engine starts but stops after a few minutes, repeat the bleeding process and check for leaks and weak connections.

COOLANT SYSTEM

The normal operating temperature of the engine is 180° - 200°. Abnormally high operating temperatures and overflow loss commonly indicate the radiator is clogged with rust and sludge or radiator fins are clogged with dirt. In this situation, you may want to use the reverse flow flushing procedure listed below. Reverse flow flushing is performed after the radiator has been flushed with a cleaning compound.

The following maintenance is required to keep the coolant system operating efficiently:

- Check the coolant level each day.
 - Drain and flush the coolant system every 500 hours of operation.
 - Inspect the radiator fins for cleanliness every 50 hours of operation. Blow out the radiator fins if clogged.
-

SERVICE INSTRUCTIONS



WARNING.

Never attempt to perform any service on the equipment or components until the engine is OFF, the parking brake is LOCKED, and the wheels are CHOCKED.

BLOWING OUT RADIATOR FINS

NOTE: Make sure the radiator is cool before blowing out the radiator fins with compressed air.

REVERSE FLOW FLUSHING

1. At the engine, disconnect the hoses.
2. Make sure the radiator cap is on tight.
3. Using a hose clamp, clamp a flushing gun onto the lower hose.
4. Turn on the water and fill the radiator.
5. To keep from damaging the radiator, apply air pressure slowly and carefully.
6. Shut off the air pressure, refill the radiator with water, and reapply the air pressure. You will need to repeat these steps until water flushed from the radiator runs out clear.

7. Inspect and clean the radiator cap.
8. Inspect and reinsert the hoses.
9. Fill the radiator with coolant.

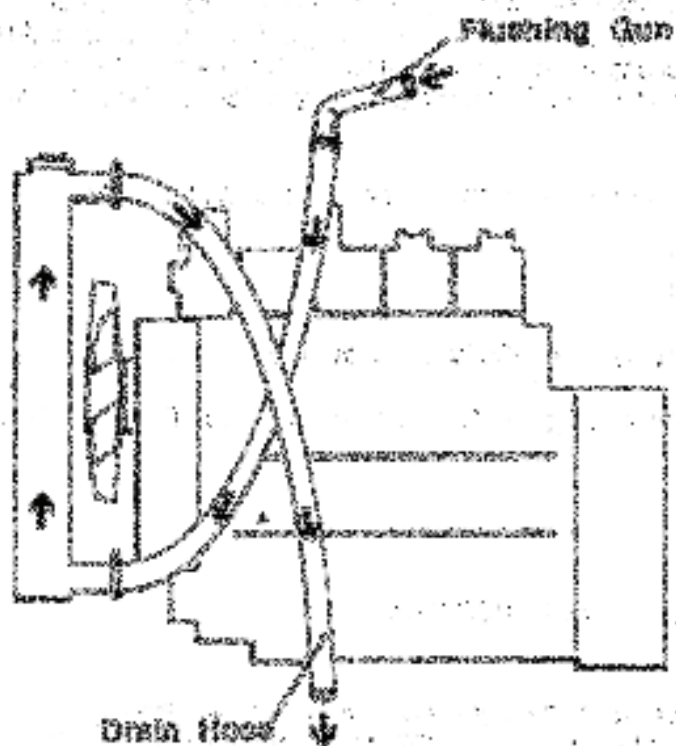

NOTE: Use a 50/50 mixture of water and an anti-freeze with an ethylene glycol base.

SAE LUBRICATION

Lubrication of PowerBoss™ tractors requires the following:

- Check the engine oil level each day.
- Replace engine oil and filter every 200 hours, or more frequently in extremely dusty operating environments.
- Use oil which meets API SD or SE specifications, and which is suited to seasonal temperatures. (Refer to charts below.)
- Follow the recommended lubrication schedule for bearings, grease fittings, and other key lubrication points.

Gasoline and LPG Engines: Use any SD or SE rated oil meeting API specifications and suited to seasonal temperatures.

Temperature	SAE Viscosity
Below 5° F (Below -17° C)	5W-20, 5W-30
0 to 75° F (0 to 24° C)	5W-20, 10W, 10W-30, 10W-40, 20W-20, 20W-40
Above 75° F (Above 24° C)	10W-30, 30W-50

Diesel Engines: Use only CD or CE rated oil. Multigrade oil should meet single grade requirements for seasonal temperatures.

Temperature	SAE Viscosity
Below 5° F (Below -17° C)	5W, 5W-20, 5W-30
0 to 32° F (-17° to 0° C)	10W, 10W-30, 10W-40
32° to 75° F (0° to 24° C)	20W, 10W-30, 10W-40
Above 75° F (Above 24° C)	30, 10W-30, 10W-40

SERVICE INSTRUCTIONS

WARNING

Never attempt to perform any service on the equipment or components until the engine is OFF, the parking brake is LOCKED, and the wheels are CHOCKED.

CHANGING ENGINE OIL

NOTE: The engine oil drain plug is located at the bottom of the engine pan.

1. **Low Dump Models:** Remove the hopper and place the drain pan beneath the plug in the engine pan.
High Dump Models: Raise the hopper and engage the safety arm.

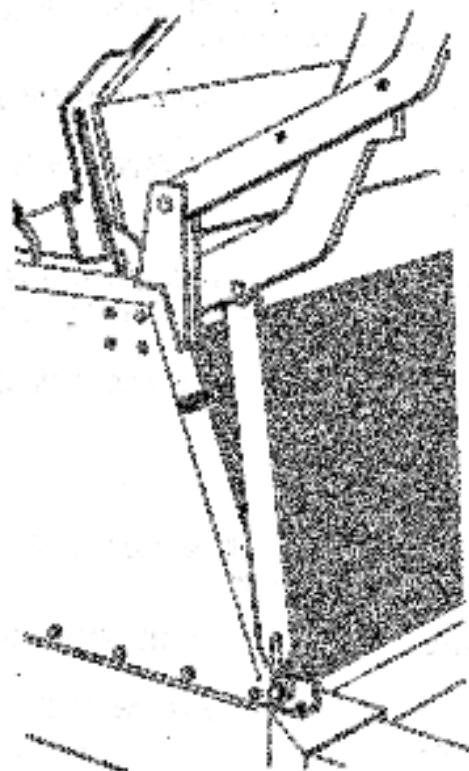

 **WARNING:** Never place your hands or body parts under a raised or partially raised hopper unless the safety arm is in place.

2. Remove the drain plug and allow oil to drain into the pan.
3. Replace the drain plug.
4. Remove the used oil filter and replace with a new one.
5. Remove the engine oil cap, add oil in the amounts listed in engine manual, then secure the cap.

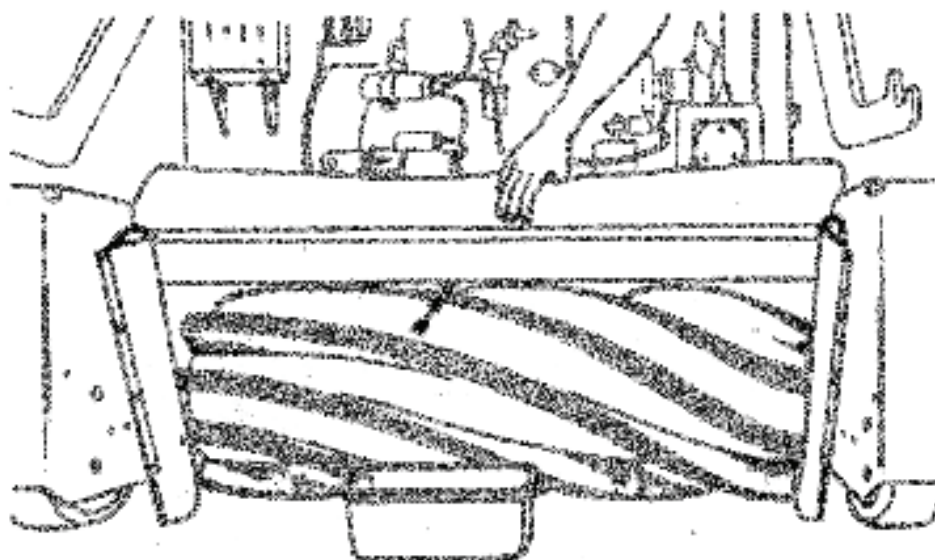

LUBRICATION POINTS

The chart on the next page outlines additional lubrication requirements for PowerBoss™ sweepers. Refer to the chart for assistance in locating key lubrication points.

LUBRICATION CHART

Lubrication	Type of Lubrication	Frequency (in Hours)
Impeller Bearing Housing 68 (2 fittings) 78 (1 fitting)	Lubriplate EMB or Chevron SRI #2	100

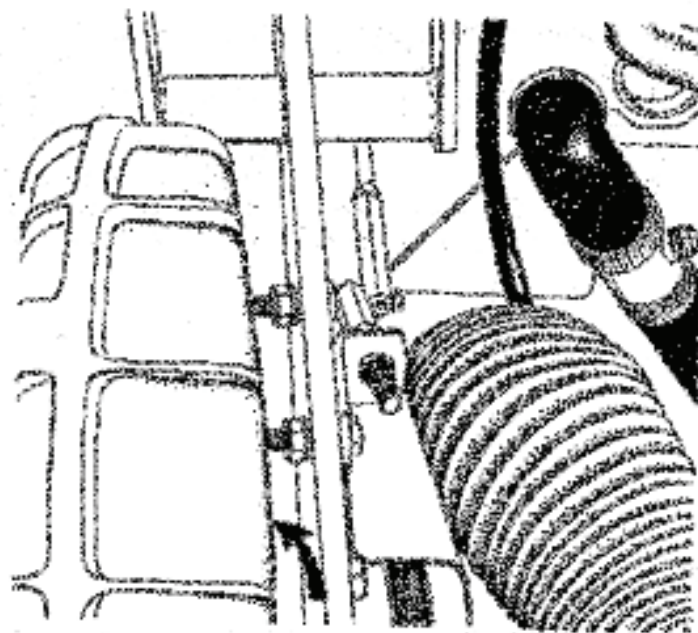

Lubrication

Type of Lubrication

Frequency
(in Hours)

Steering Gear Box,
(1 fitting)
Steering Link Arm,
(2 fittings)
Steering Fork Assembly
(1 fitting)

Lithium Grease

500

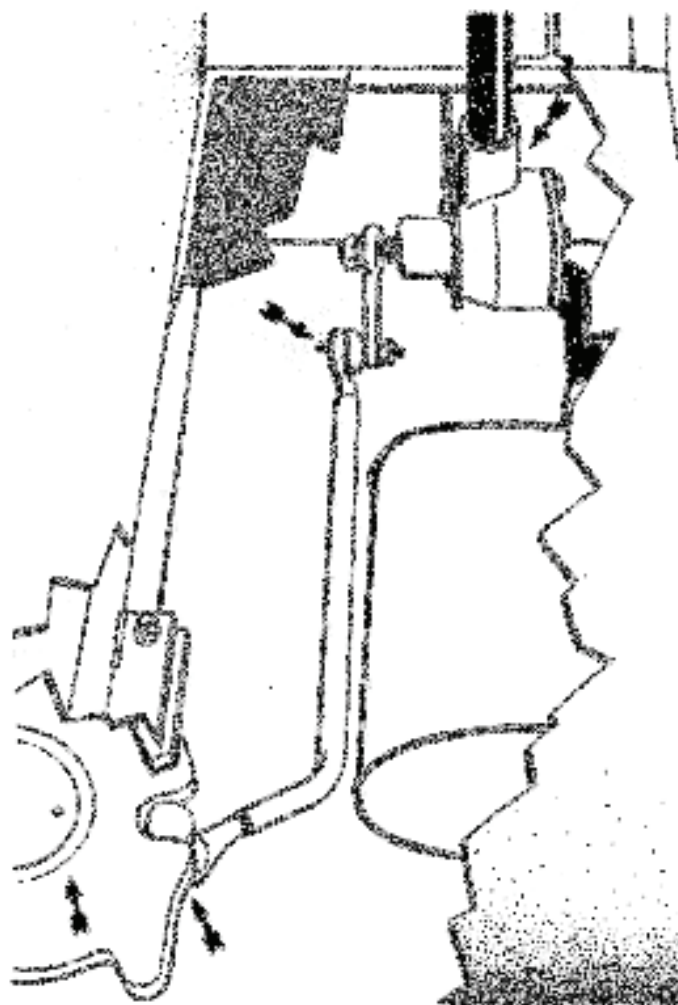

Pilow Block Supporting
Drive Mechanism
(2 Billets)

Lithium Grease

500

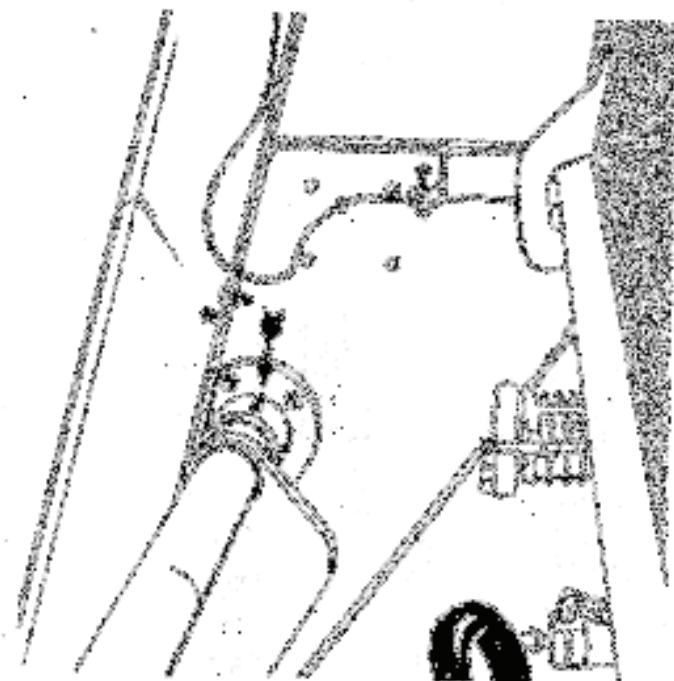

Hood Latches and Hinges

Oil

500

HYDRAULICS SYSTEM

To keep the hydraulics system in good condition, the following maintenance is required:

- Check the sight gauge of the hydraulic fluid reservoir daily and fill the reservoir as needed.
 - Blow off and pressure wash the cooling coil (located at the exit port of the impeller fan) every 100 hours of operation.
 - Replace the filter/breather cartridge every 500 hours.
 - Change the hydraulic fluid and filter every 500 hours of operation.
 - Check the functioning of the directional control pedal periodically and adjust the neutral setting position and the speed limiter if needed.
-

SERVICE INSTRUCTIONS



WARNING

Never attempt to perform any service on the equipment or components until the engine is OFF, the parking brake is LOCKED, and the wheels are CHOCKED.

FILLING THE FLUID RESERVOIR

NOTE: The reservoir is located inside the machine and is accessible through the top side door. When the machine is cool and the hopper is in the lowered position, the sight gauge on the face of the reservoir should be two-thirds full.

1. Remove the filter/breather cartridge located on top of reservoir.
2. Fill the reservoir two thirds full with fluid that meets the viscosity specifications indicated below, then replace the filler cap.

NOTE: Do not use transmission fluid in place of hydraulic fluid.

Hydraulic Fluid Viscosity Specifications

SUS @ 100° F	40-44S
SUS @ 210° F	73-84

MAINTAINING COOLING COIL EFFICIENCY

The cooling coil is located at the exit port of the impeller fan and utilizes exhausted impeller air to cool the hydraulic fluid. To maintain its efficiency, periodically blow off the cooling coil with compressed air and pressure wash the cooling coil every 100 hours of operation.

CHANGING THE HYDRAULIC FLUID

1. Turn off the engine and engage the parking brake.
2. Place a drain pan on the floor below the reservoir.
3. Remove the drain plug located on the bottom rear of the reservoir and allow the fluid to drain.
4. Discard the fluid, then replace and reighten the drain plug.
5. Remove the filter/breather cap located on top of the reservoir and fill the reservoir with approved hydraulic fluid.

NOTE: This will require six gallons of fluid.

6. Check the sight gauge to insure the proper two-thirds level is achieved.
7. Install a new filter/breather cartridge.
8. Check the drain plug for leakage.

A - Filter/Breather Cartridge

B - Hydraulic Reservoir

C - Hydraulic Level Sight Gauge

D - Hydraulic Filter

E - Hydraulic Filter Condition Indicator

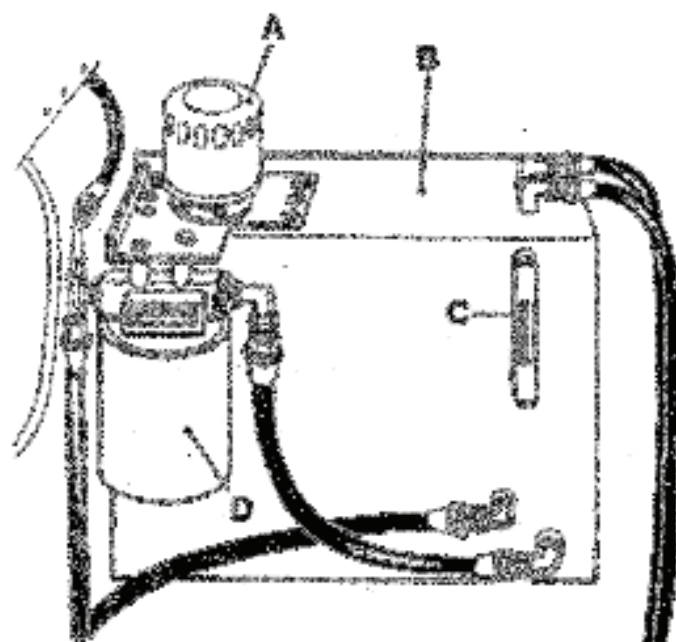

CHANGING THE HYDRAULIC FLUID FILTER

1. Turn off the engine and engage the parking brake.
2. Unthread the oil filter cartridge from the mount and discard.
3. Apply a thin coating of fluid to the seal of a new filter element.
4. Thread onto the mount and hand tighten.
5. Tighten an additional one-half turn beyond hand tight.

NOTE: Do not overtighten.

6. Start the machine, shut it off, then check for leakage.

ADJUSTING THE DIRECTIONAL CONTROL RETURN SPRING

You may encounter "creeping" problems from time to time. Creeping means the machine moves backward or forward when the forward/reverse pedal is in neutral. A grinding noise when the engine is shut down is also an indicator that the directional control return spring needs adjusting. If this occurs, perform the procedure which follows.

1. On low dump models, remove the hopper. On high dump models, raise and engage hopper safety arm.

 **CAUTION:** For maintenance on high dump models, do not rely on the hydraulic cylinder to keep the hopper raised. Always engage the safety arm before going under the hopper.

2. Turn off engine, engage parking brake, and chock both wheels.
3. Jack the rear of the machine so that the rear tire just clears the floor. Use two jack stands to support the machine. **DO NOT USE JACK ALONE TO HOLD THE MACHINE UP.**
4. If an assistant is not available to watch the rear wheel, use a mirror to allow you to see the rear wheel.

(Continued on next page.)

6. Locate the forward/reverse adjustment bracket mounted between the pump on the pump mounting plate.

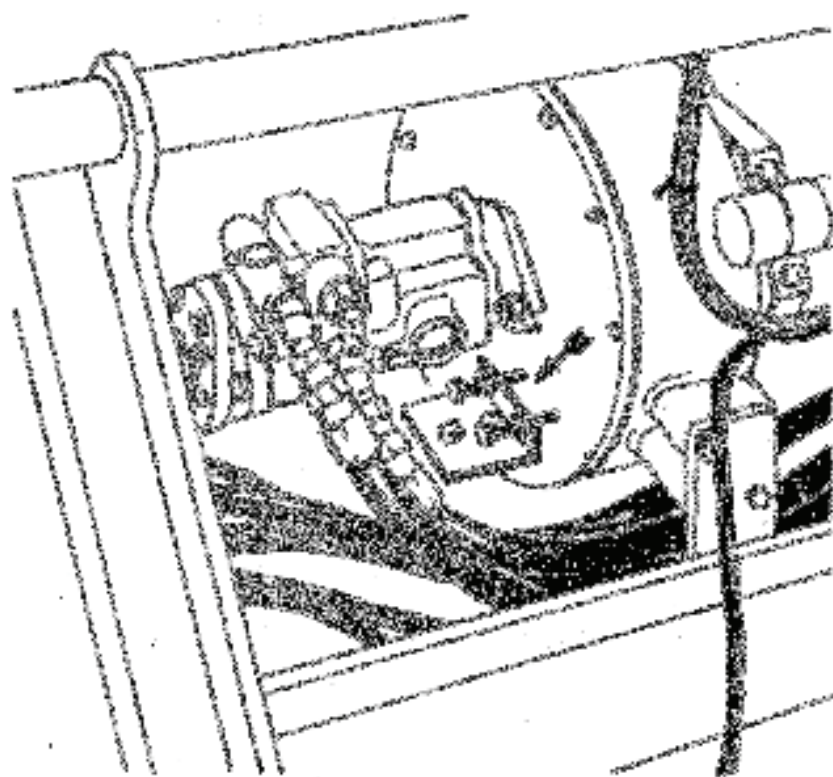

6. Slightly loosen the bolt on the center of the bracket.
7. Now loosen the locking nut on each of the adjusting bolts on the side of the bracket closest to the pump mounting plate.
8. From the operator's seat, start the engine and run at half throttle.
9. Turn the adjusting bolts while watching the rear wheel. Continue to adjust until the rear wheel does not turn in either direction.
10. Fully open throttle. Push the directional control pedal forward and backward to be sure pump stays in neutral. Check wheel again and adjust as needed until the wheel remains motionless.
11. Retighten all the locking nuts and the bolts.
12. Turn engine off and lower the machine to the floor.

ADJUSTING MACHINE SPEED

To limit the speed of the machine, simply reposition the speed limiter, a bolt underneath the directional control pedal which can be moved in or out. Be sure that the directional control pedal contacts the speed limiter bolt before the pump control arm hits the pump stop.

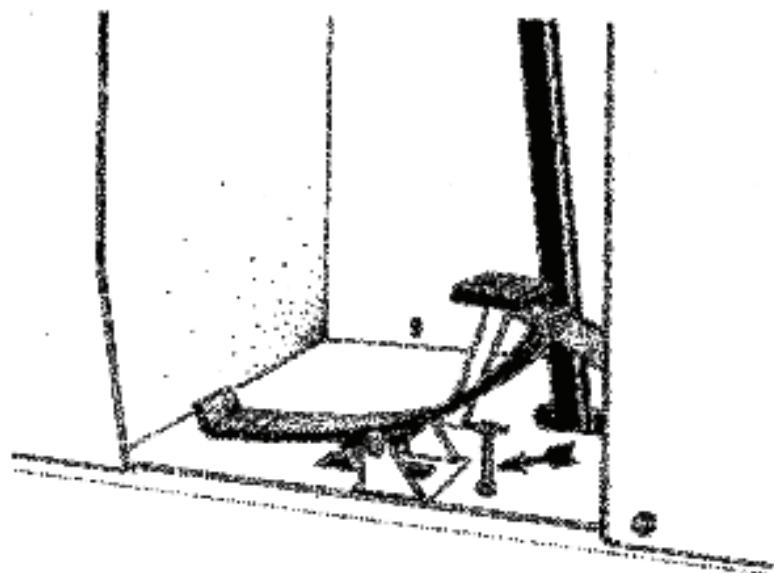

HYDRAULIC SCHEMATICS

Use the schematics which follow to assist you in troubleshooting and maintaining the hydraulic system of the sweeper.

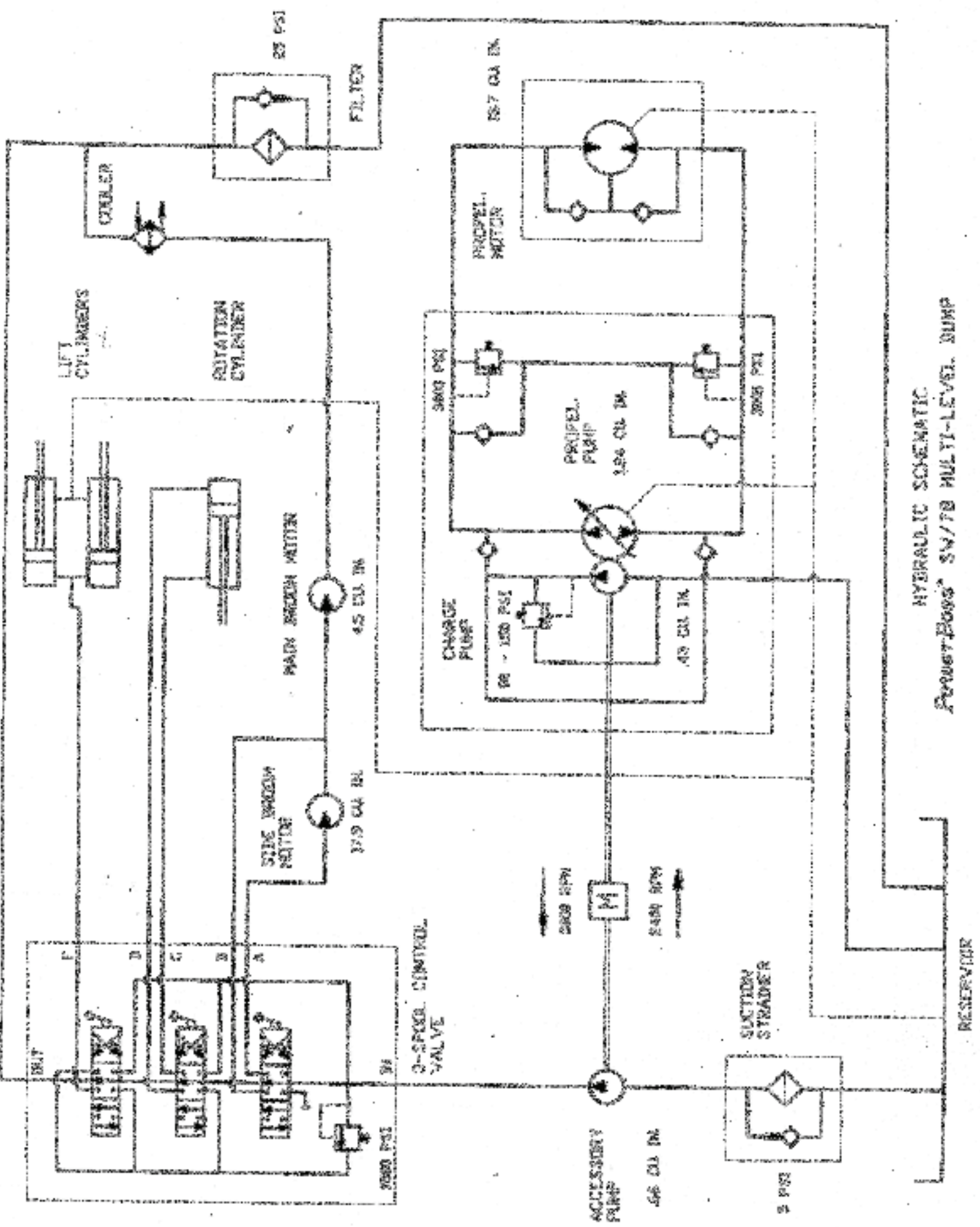

HYDRAULIC SCHEMATIC
 PowerBoys® SW/70 MULTI-LEVEL DUMP

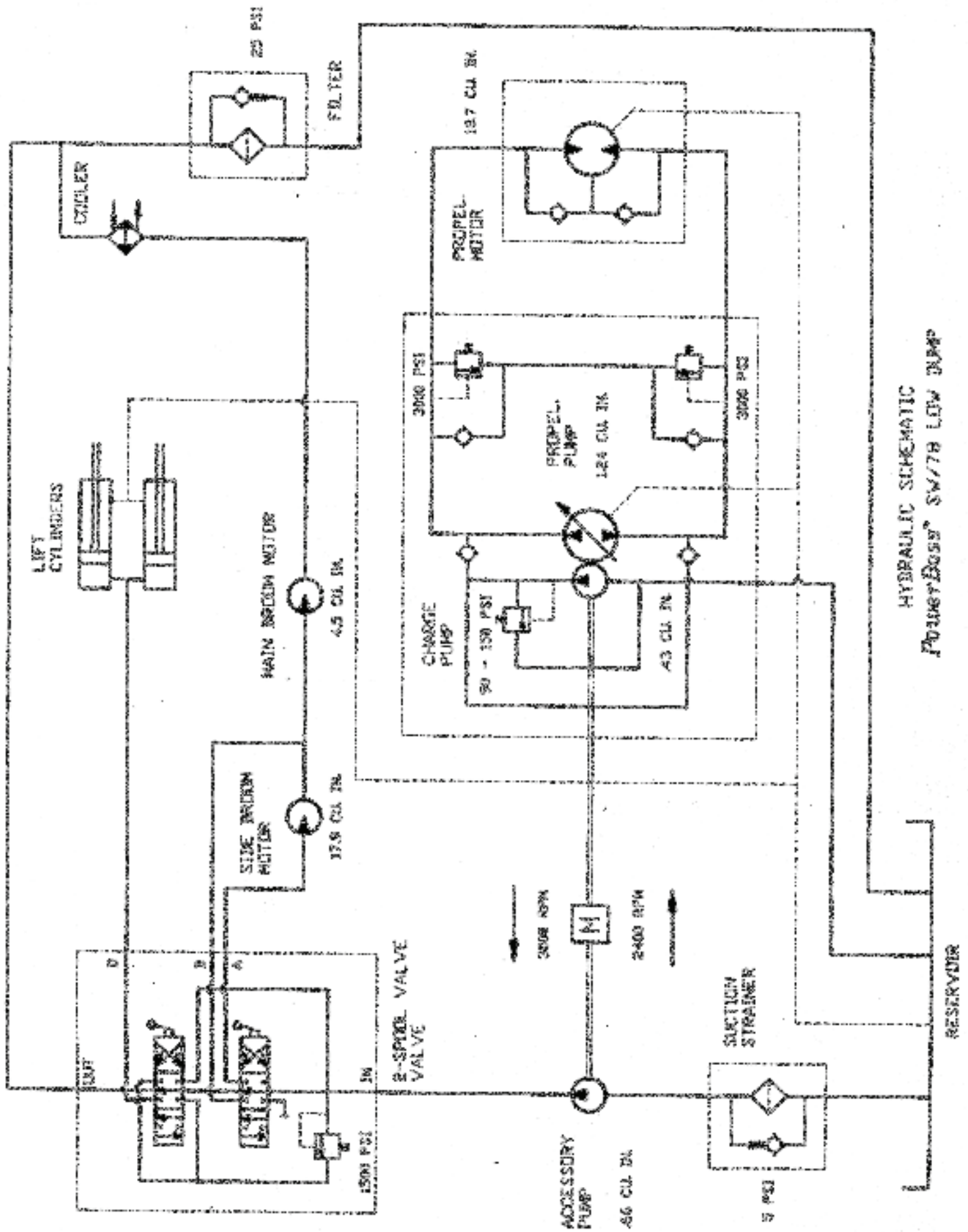

HYDRAULIC SCHEMATIC
PowerBose® SW78 LOW DUMP

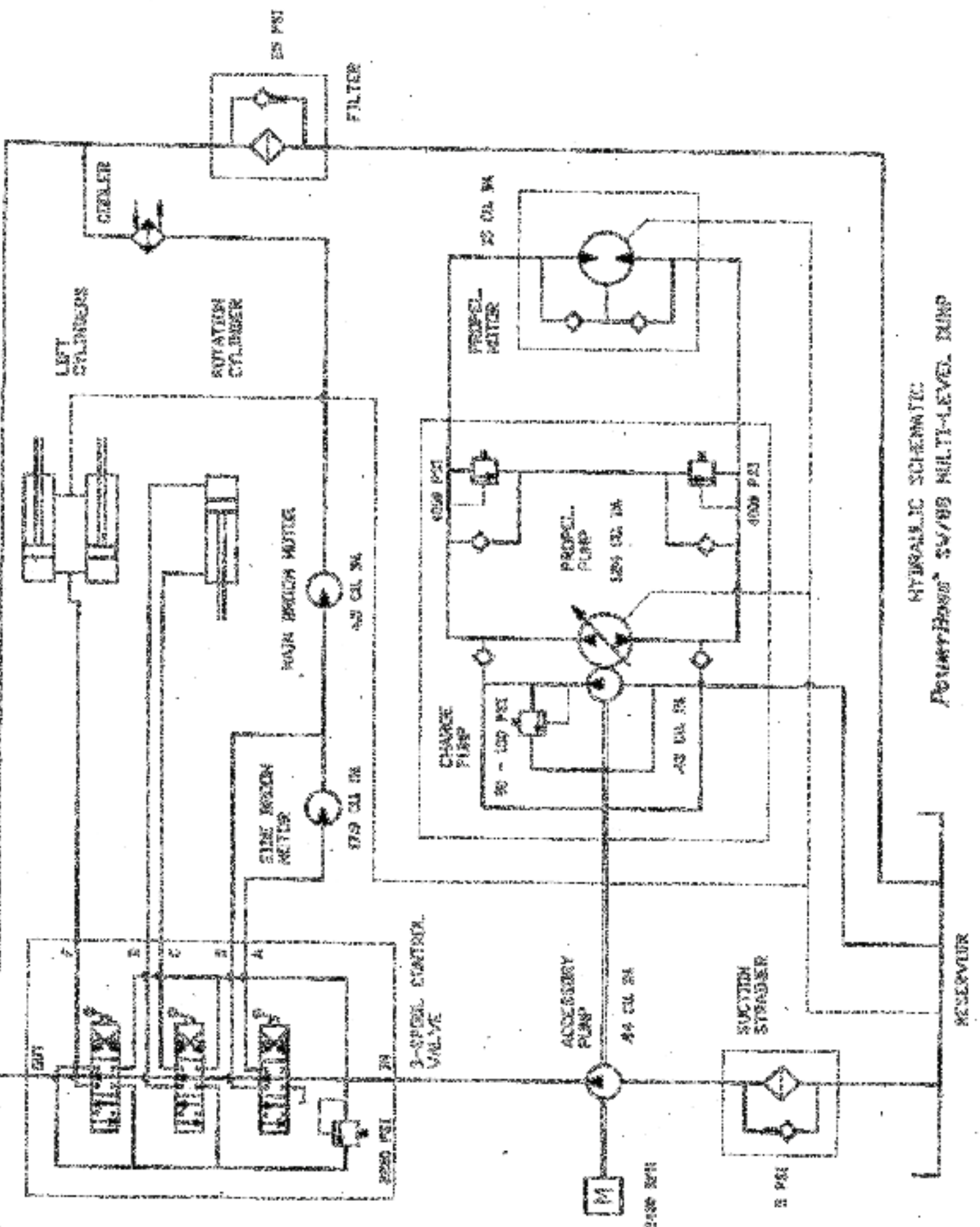

HYDRAULIC SCHEMATIC
 PowerBoss® 3V/8S MULTI-LEVEL DUMP

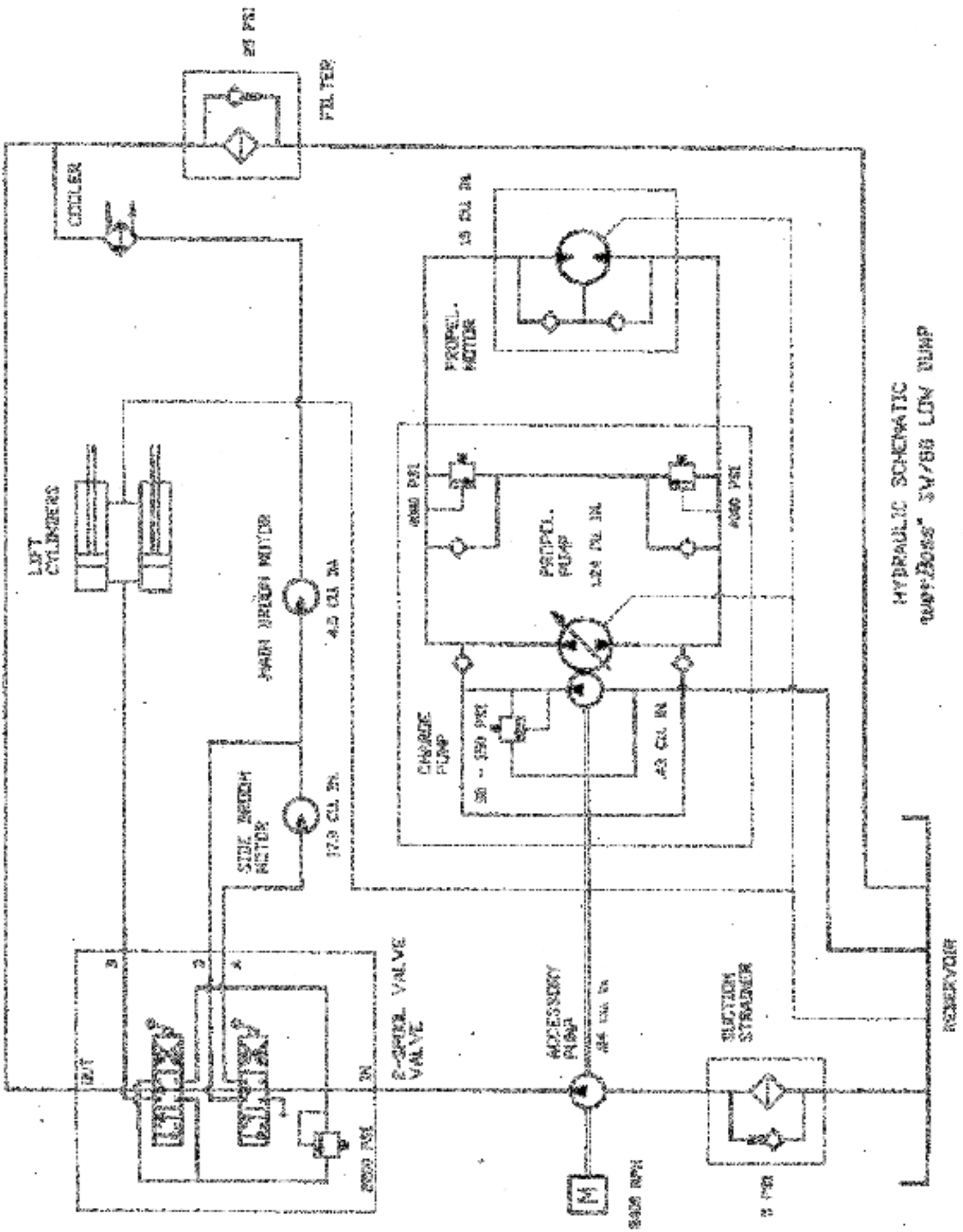

HYDRAULIC SCHEMATIC
PowerBoss™ 3V/50 LHM PUMP

VACUUM SYSTEM

To keep the vacuum system in good condition, you will need to perform the following maintenance:

- Check the tension of impeller belts after every 50 hours of operation and tighten the belts as needed. On 78 models, dual belts are used between the engine and auxiliary hydraulic pump. If one belt breaks, both belts must be replaced, so be sure to purchase a matched set.
 - After every 100 hours of operation, check to make sure the bottom pulley is aligned with the pulley on the engine. If pulleys are not properly aligned, belts cannot properly function.
 - Lubricate impeller bearing housings after every 100 hours of operation; 88 models have two housings, 78 models have one.
-

SERVICE INSTRUCTIONS



WARNING

Never attempt to perform any service on the equipment or components until the engine is OFF, the parking brake is LOCKED, and the wheels are CROCKED.



CAUTION: If the engine must be started for test purposes, do not put your hands near drive hoses or springs or near the impeller or belts.

BELT TENSIONING

Engine to Jackshaft Belt 88 Models

1. Locate the impeller belt tensioning bar bolted to the engine block.
2. Locate the threaded adjustment rod attached to the tensioning bar.
3. Loosen the nut on the threaded rod closest to the engine.

(Continued on next page.)

4. With this nut loosened, place a wrench on the nut located on the threaded rod on the opposite side of the tensioning bar. Tighten or loosen the bolt as needed using this nut.
5. After the adjustment is complete, retighten the first nut.

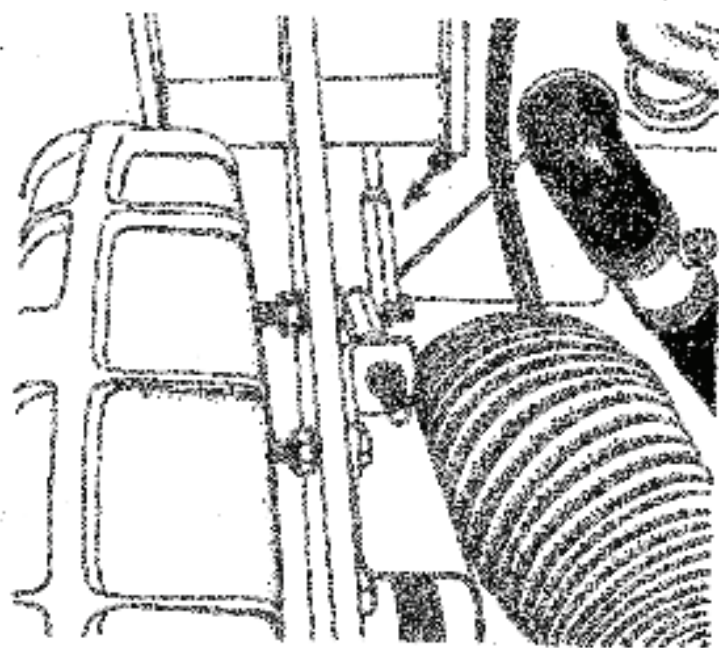

Engine to Jackshaft Belt
78 Models

1. Locate the tensioning rod (it runs through the cooling coil).
2. Loosen the nut closest to the cooling coil.
3. With the nut loosened, place a wrench on the nut located on the opposite side of the bracket. Tighten or loosen the belt as needed using this nut.
4. After the adjustment is complete, retighten the first nut.

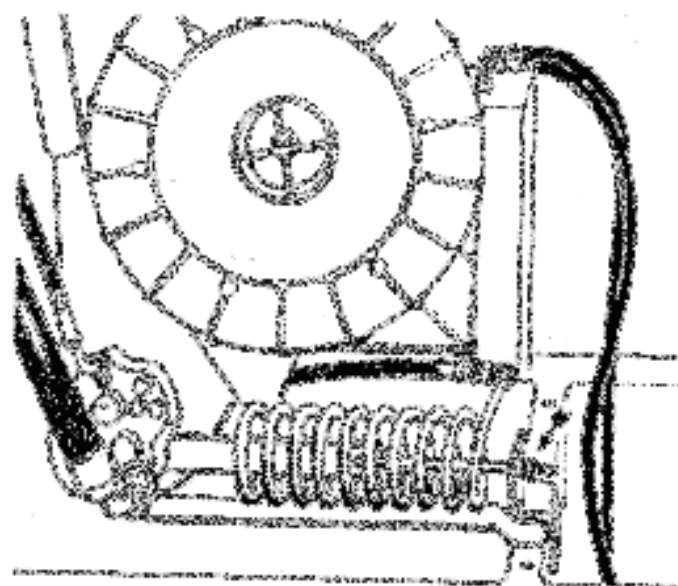

Jackshaft to Impeller Belt 66 and 73 Models

1. Locate the impeller belt tensioning bracket on the back side of the impeller.
2. Slightly loosen the nut and bolt securing this bracket (about one turn).
3. Locate the threaded adjusting rod that runs through this bracket and loosen the nut directly on top of the bracket and threaded onto the rod.
4. With this nut loosened, place a wrench on the nut directly below the adjustment bracket on the threaded rod. Tighten or loosen the belt as needed using this nut.
5. After the adjustment is complete, retighten the nut on top of the bracket.
6. Retighten the nut and bolt that attach the impeller belt tensioning bracket.

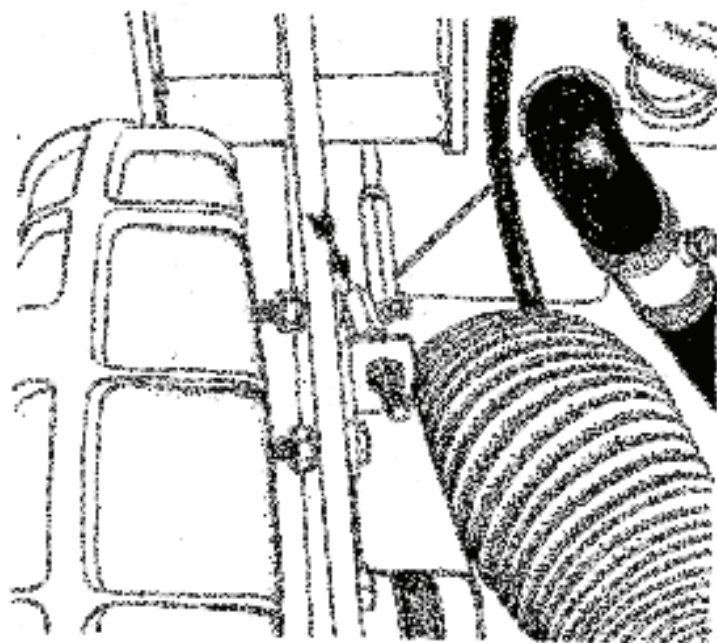

PULLEY REALIGNMENT

1. Check pulley alignment by placing a straight edge against and between the two pulleys. The straight edge should be flat against the outer surface of both pulleys. If a gap between pulley and straight edge is evident at either end, an adjustment is needed.
2. You can bring the impeller pulley and jackshaft pulley into alignment by adding washers onto the impeller pivot mount. The jackshaft pulley and the engine pulley can be brought into alignment by sliding the impeller mounting bracket in its mounting slots.

LUBRICATION OF IMPELLER BEARING HOUSINGS

1. Grease bearing housing with Lubriplate EM3 or Chevron SR1 #2.

ATTENTION! Be careful not to overfill the housings. This will cause grease to be thrown onto the bells and parleys which drive the impeller. Any excess grease expelled from these bearings should be wiped away.

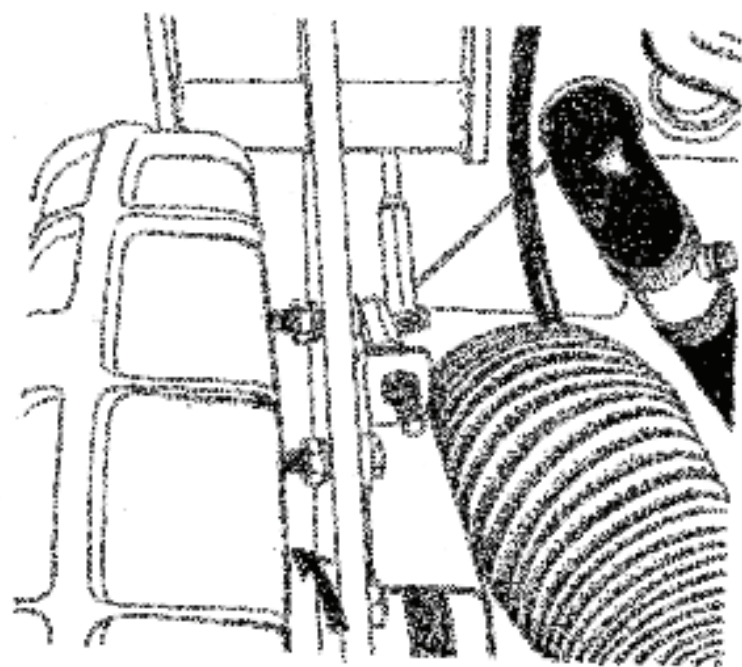

SWEEP COMPONENTS

The following maintenance is required to assure maximum cleaning efficiency and service life of sweep components:

- Inspect brooms daily for wear. Remove any strings, wires, or other debris entangled in the bristles or drive assembly.
 - After every 50 hours of operation:
 - Inspect broom skirts for wear and replace as needed.
 - Rotate the main broom end-to-end.
 - Perform the main broom adjustment test and adjust as needed.
 - Inspect the side broom for proper angle and contact and adjust as needed.
 - Perform taper adjustment when the main broom adjustment test indicates it is necessary.
 - Replace main broom when bristles wear to a length of 1". Replace side broom when bristles wear to a length of 3".
-

SERVICE INSTRUCTIONS

WARNING

Never attempt to perform any service on the equipment or components until the engine is OFF, the parking brake is LOCKED, and the wheels are CHOCKED.

BROOM DOOR FLAP INSPECTION

NOTE: Perform this inspection when the machine is parked on a level surface.

1. Turn the machine off and lock the parking brake.
2. Inspect broom door flap for wear and damage. Flap clearance should be 1/8" above the floor.
3. Worn and damaged flaps should be replaced immediately to maintain proper dust control.

(See illustration, next page.)

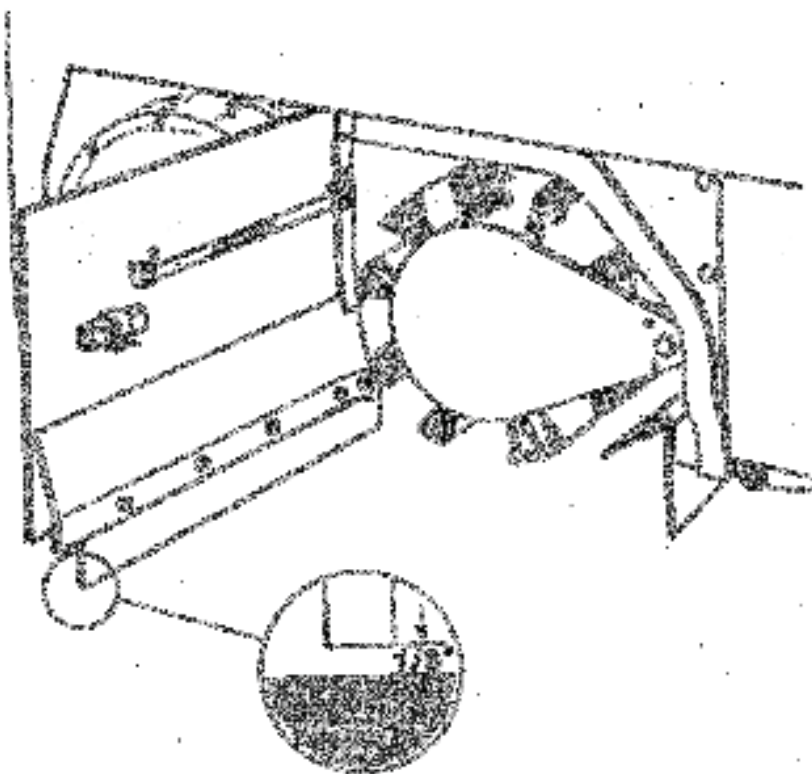

BROOM DOOR FLAP REPLACEMENT AND ADJUSTMENT

The flaps are attached to the broom doors by a retainer bar and hex bolts and nuts. To remove the flaps, remove nuts and bolts and retainer bar. To adjust flaps, loosen nuts and bolts, slide flap up or down as needed. Tighten nuts and bolts.

MAIN BROOM ADJUSTMENT TEST

NOTE: Perform this adjustment on a flat, smooth test surface.

1. Drive the machine onto the test surface with the main broom in the RAISED position.
2. Set the parking brake and position the main broom handle to NORMAL position.
3. Push the broom control lever to ON position to activate the broom motor and open throttle to full RPM.
4. Allow about 45 seconds for the broom to operate, then deactivate the broom motor and raise the broom.

NOTE: Test time will vary according to the test surface used.

(Continued on next page.)

5. Drive the machine clear of the test area.
6. Examine the polished pattern made by the broom on the test area.

NOTE: A rectangular shape the length of the main broom, 2" wide, indicates the main broom is properly adjusted. A pattern smaller than 2" indicates need for lower adjustment. A pattern wider than 2" indicates a need for higher adjustment. If pattern is tapered from end to end instead of rectangular, see Taper Adjustment on the next page.

Main Broom Test Pattern



MAIN BROOM ADJUSTMENT

1. Turn the machine off and lock the parking brake.
2. Position the main broom lever in the full FLOAT position.

NOTE: The adjustment knob is located under the engine cover immediately beside the battery on the firewall.

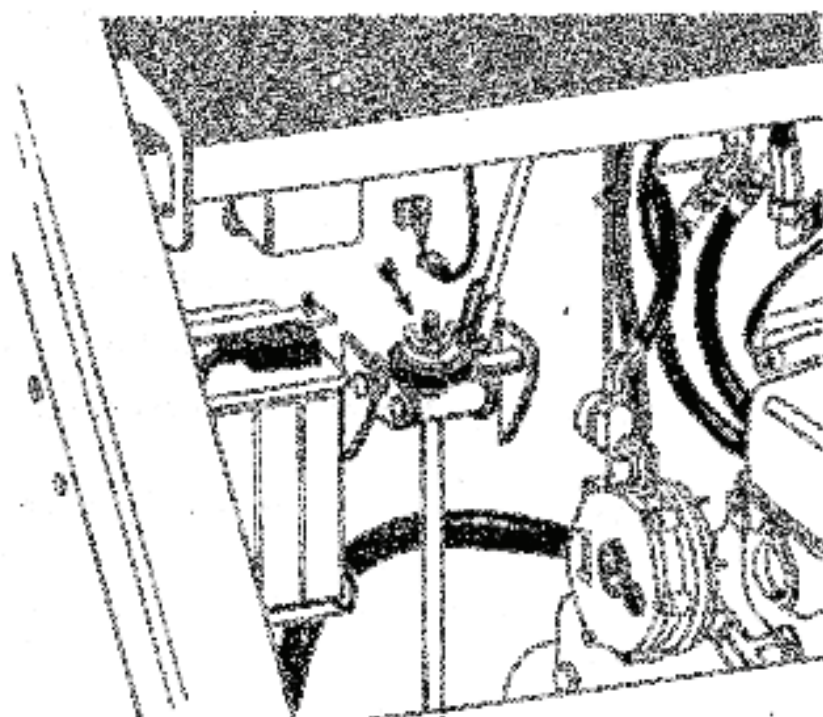

3. Turn the broom adjusting knob clockwise one-eighth turn to free wingnut.
4. Turn the wingnut counterclockwise to allow space for adjustment.
5. Make a lower or higher adjustment with the knob as required.
6. Retighten the wingnut.
7. Repeat the main broom adjustment test to see that the broom is properly adjusted.

MAIN BROOM TAPER ADJUSTMENT

NOTE: It is not usually necessary to perform this adjustment. However, if the main broom adjustment test shows a pattern that is tapered in length (one end is wider than the other), perform the procedures which follow.

(Continued on next page.)



Correct Taper Pattern

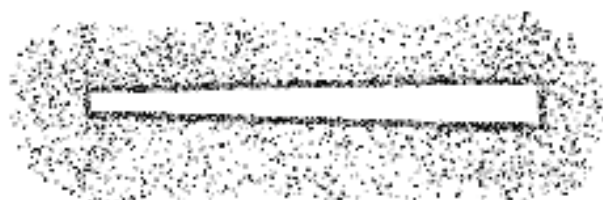

Incorrect Taper Pattern

1. Locate the hex-shaped adjustment bar on the left rear wall of the broom chamber underneath the machine.

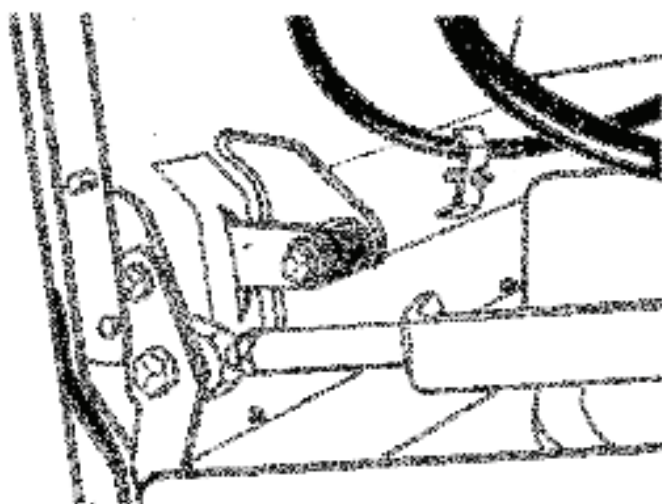

2. Loosen the locking bolt on the right side of the hex bar.
3. Grasp the hex bar with a wrench and rotate it to raise or lower the left end of the main broom. (The right end of the main broom remains fixed. All adjustments affect the left end of the broom.)
4. After adjustment, retighten the bolt.
5. Repeat the main broom adjustment test to see that the broom is properly adjusted.

SIDE BROOM ADJUSTMENT INSPECTION

Inspect the side broom for proper angle and contact with the floor. Optimum side broom angle is 5°. Proper contact is achieved when the bristles contact the floor from 3:00 to 10:00 as shown in drawing.



SIDE BROOM HEIGHT (WEAR) ADJUSTMENT

1. Stop the engine and lock the parking brake.
2. Position the side broom handle in LOWER position.
3. Loosen the side broom adjusting nuts located on the exterior of the side broom arm assembly.

(Continued on next page.)

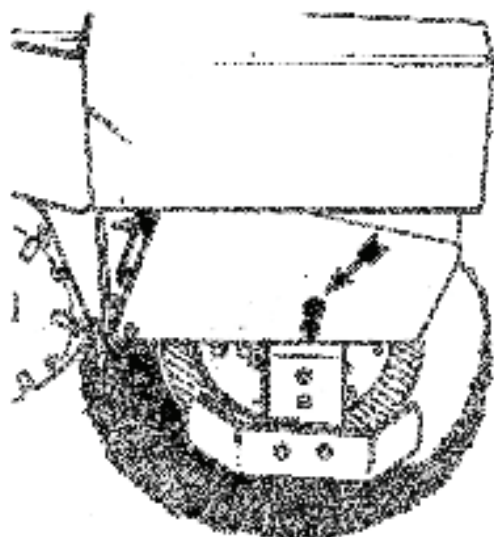

4. Adjust the side broom height by sliding the broom assembly up or down until proper floor contact is made.
5. After adjustment, tighten the adjusting nut.

SIDE BROOM ANGLE ADJUSTMENT

NOTE: This adjustment is controlled by a bolt located on the inside of the side broom arm assembly. By turning this bolt, the angle at which the bristles contact the floor can be changed. The optimum angle is 6°.

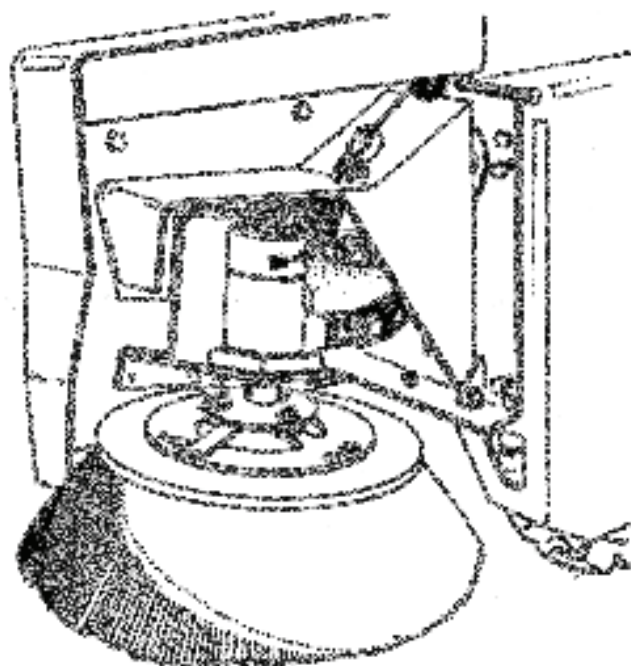

SIDE BROOM LIFT CABLE ADJUSTMENT

This adjustment is made at the hex-shaped adjustment bar attached to the side broom lift lever in the engine compartment. It controls the height of the side broom when raised.

On high dump models, this adjustment must be performed with the hopper fully lowered.

1. Pull the side broom lever into the raised position.
2. Loosen the locknut on the hex bar.

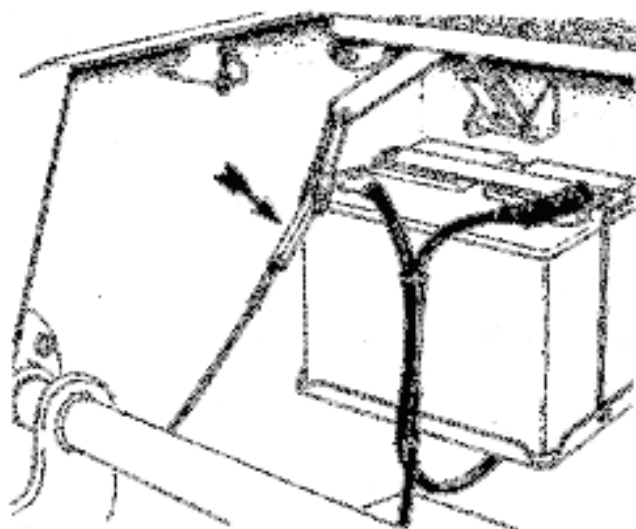

3. Turn the cable in or out of the hex bar as necessary to set the side broom in the maximum raised position.
4. Secure the cable adjustment by tightening the locknut against the hex bar.

MAIN BROOM REPLACEMENT

1. Turn the engine off and lock the parking brake.
2. Push the main broom control lever to the NORMAL position.
3. Open the left broom chamber door (the door opposite the driver's side).
4. Using the wrench stored inside the broom chamber door, remove the hex bolt on the main broom idler mount.
5. Pull the main broom idler mount straight out to remove.

6. Grasp the main broom by the plastic drive hub, pull the main broom straight out and clear of the broom chamber.
7. At this point, depending on broom condition, you can either rotate the old broom end-for-end and re-install it or you can install a new broom. In either case, you need to slide the main broom into the broom chamber and align the broom with the metal drive hub located at the far side of the broom chamber.

If a worn broom is being replaced, it may be easier to install the new broom by first adjusting the broom arms up, to better match the position of the drive hub with the hub on the new broom.
8. Once the broom is started onto the drive hub, rotate the broom counterclockwise while pushing lightly against the broom.
9. Once the broom is fully engaged, replace the idler hub while aligning the seats in the idler hub with the broom's drive hub ears.
10. Install the retaining bolt into position and tighten with the wrench.
11. Return the wrench to its storage hooks on the inside of the broom chamber door.
12. Close and latch the left broom door.
13. Perform a main broom adjustment test and adjust as needed.

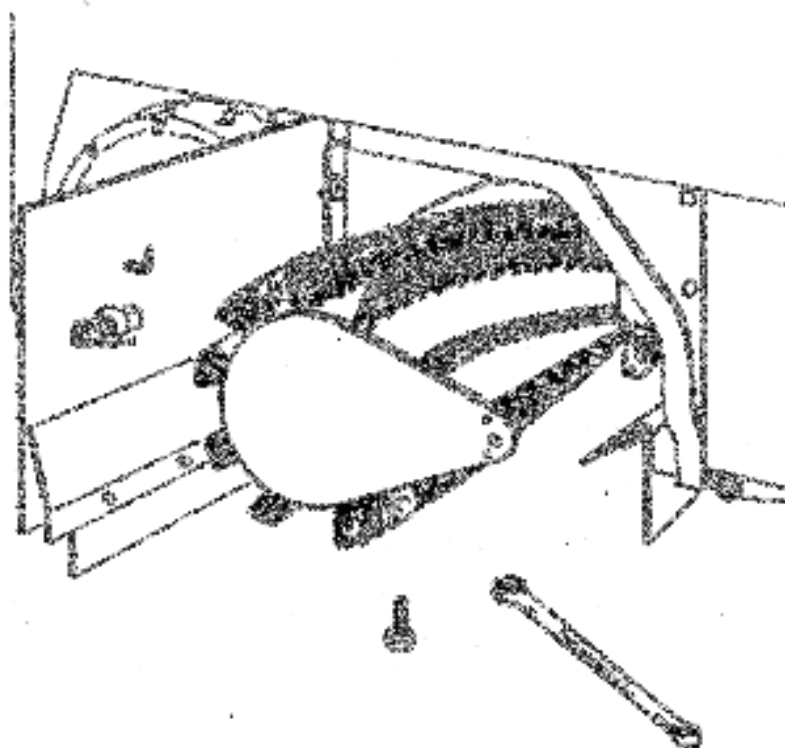

SIDE BROOM REPLACEMENT

NOTE: The side broom features a quick release mechanism which enables the operator to remove the brush in seconds.

1. Raise the side broom and lock in RAISE position.
2. Turn the side broom by hand until the brush retainer bar is accessible.
3. Lift the bar and turn the broom clockwise (about one eighth of a turn) until the lock pins in the broom disengage from the drive plate.
4. Install the new broom by positioning three drive pins into the pilot holes of the drive plate.
5. Lift and rotate the broom until the broom retainer bar springs into the locked position.
6. Check to make sure all three drive pins are properly engaged.

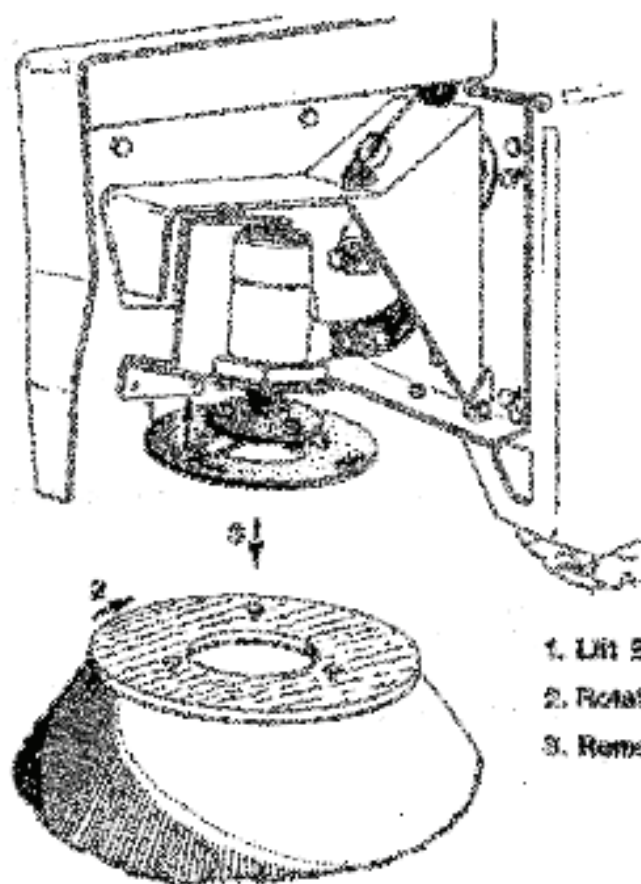

1. Lift Brush Retainer
2. Rotate Broom
3. Remove Brush

HOPPERS

The following maintenance is required to assure maximum cleaning capacity of hoppers and tanks:

- Check hopper filters and clean or replace as needed.
 - Check hopper clearance from floor and adjust as needed.
 - Inspect hopper flaps daily for wear and damage and replace when needed.
 - Lubricate the dump mechanism every 500 hours of service.
-

SERVICE INSTRUCTIONS



WARNING

Never attempt to perform any service on the equipment or components until the engine is OFF, the parking brake is LOCKED, and the wheels are CHOCKED.

LOW DUMP HOPPER REMOVAL AND REPLACEMENT

The hopper must be removed on low dump models for service and maintenance. You will need a low dump hopper dolly for this procedure. To remove:

1. Park the machine on a level surface and engage the parking brake.
2. Adjust the throttle to just above idle.
3. Raise the hopper to full dump height and lock it into the raised position.
4. Turn engine off.
5. Insert the hook on top of the dolly into the opening between the bottom of the sweeper's bumper and the hopper. Position it near the center of the bumper.

NOTE: The dolly should stay attached in this position when released.

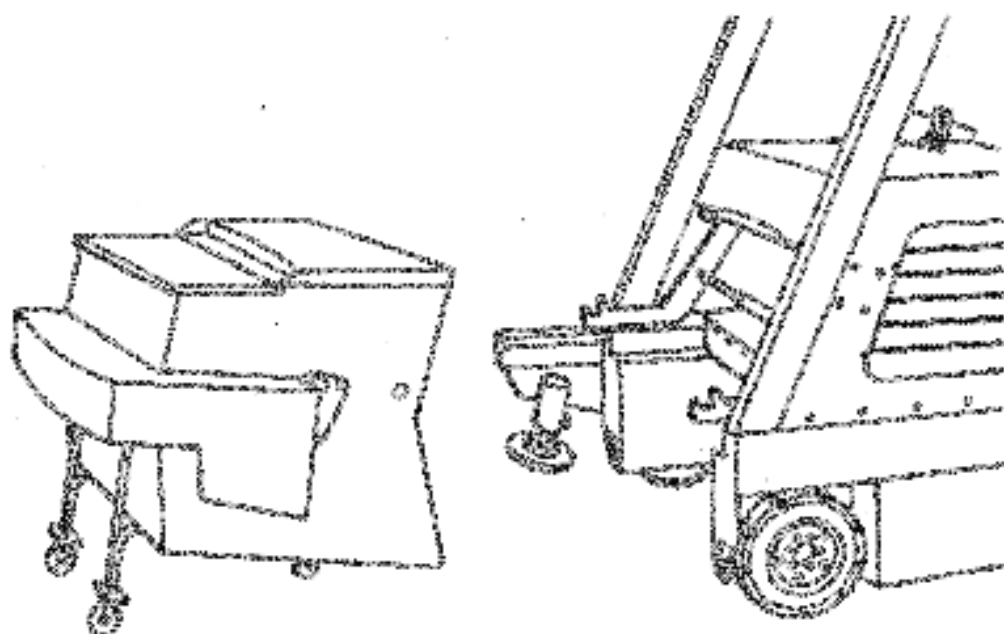

6. Return the dump lever to its center off position to lower the hopper.
7. Push down on the dump arms until the ends of the dump arms are lower than the hopper lift brackets.
8. Disconnect the wire connection at rear of hopper.
9. Grab bumper and pull the hopper straight out away from machine.

To replace:

1. Make sure the ends of the dump arms are lower than hopper lift brackets.
2. Roll the hopper between lift arms.
3. Be sure the hopper stop bars are positioned immediately above the dump arm flanges located at the rear of the dump arms.
4. Align the hopper lift brackets with the hook openings located at the front of the lift arms.
5. Start the engine and lift the dump arms slowly. When lift arms engage hopper lift brackets, lift the hopper all the way up.
6. Pull dump lever back to lock hopper in the raised position. Remove dust.
7. Lower hopper.

HIGH DUMP HOPPER REMOVAL AND REPLACEMENT

It is not usually necessary to remove or replace the hopper on high dump models. However, if it becomes necessary for maintenance or to install an option, use the following procedure to remove:

1. Park the machine on a level surface and engage the parking brake.
2. Raise the hopper and position the high dump hopper dolly, a platform truck or similar four wheeled cart under the hopper.
3. Set the hopper down on the truck and turn the engine off.
4. Cycle the rotation control handle (RH) in both positions to relieve any residual hydraulic pressure.
5. Remove two toe-handled retainers located on both sides of the hopper inside the dump door.
6. Disconnect the wire connections at the right side of the hopper.
7. While spreading dump arms slightly to clear mounting pins, roll the hopper away from machine.

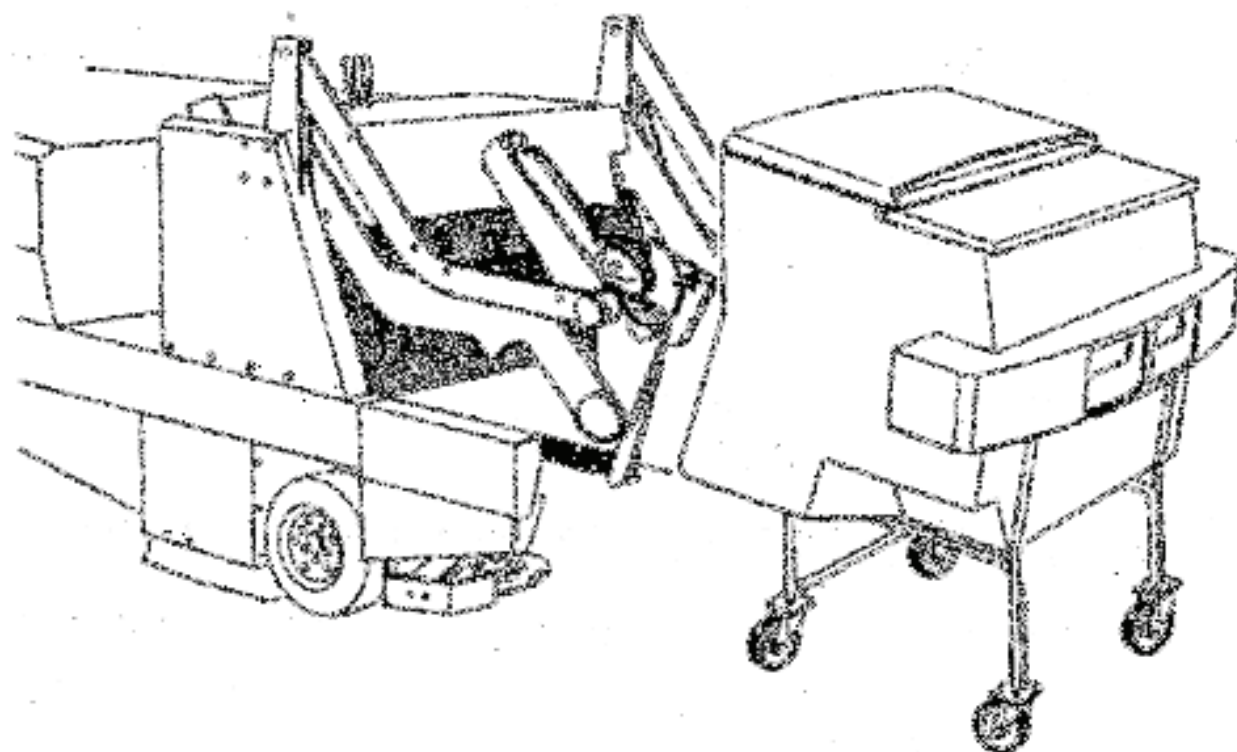

To replace:

1. Position the hopper on the dolly so as to align the mounting pins in the slots of the hopper with the rotation mounts on the arms. Lift arms should be positioned about 1/3 of way up.
2. Engage lift arm rotation plates with three mounting pins on each side of the hopper.

NOTE: The right rotation plate may have to be repositioned hydraulically to engage pins.

3. Attach the tie-handled spindle through the hopper mount hole and into the lift arms.

NOTE: Rotation mounts have holes that must engage both heads on side of hopper prior to threading in spindles.

4. Start the machine and lift hopper.
5. Drive the truck away from the hopper dolly or cart.
6. Lower hopper.
7. Engage wire connections at right side of hopper.

FILTER REMOVAL

1. Release the two latches on the hopper cover and raise cover.
2. Disconnect the wire harness leading to the filter shaker motor(s).
3. Unscrew the four knobs securing the shaker motor mount to the hopper.
4. Remove the shaker motor assembly.
5. Lift out the panel filter.

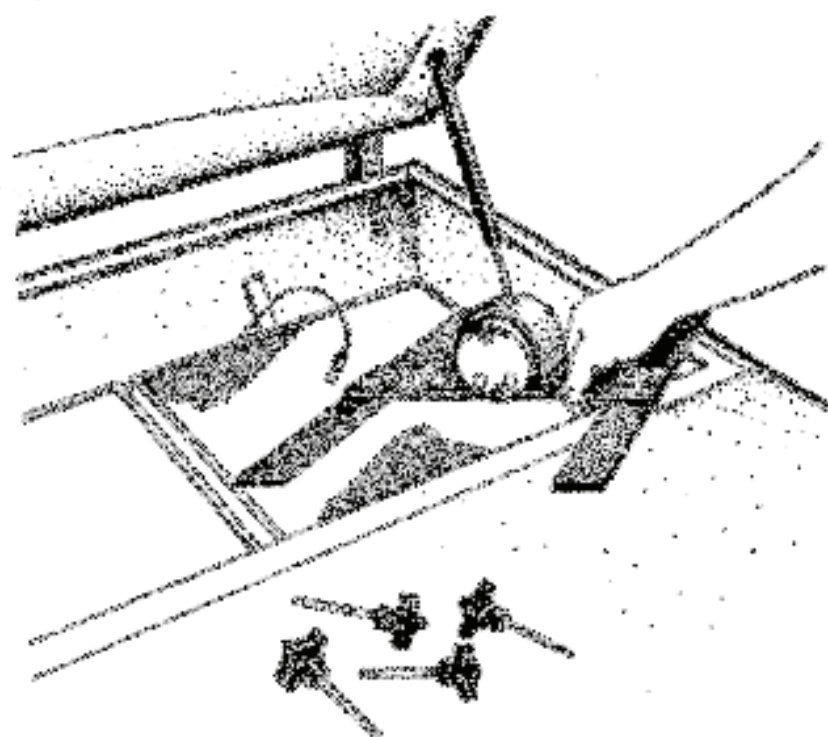

FILTER CLEANING

Filters are permanent type paper element filters. They may be vacuumed, blown out with compressed air, tapped against the floor, or washed with soap and water.

1. If blown out with compressed air, use 100 psi or less.

NOTE: Filters may be blown out while installed or removed.

2. If washed with soap and water, use 40 psi water pressure or less.

NOTE: Make sure filters are thoroughly dried while standing on their sides before installing them in the hopper. Do not install or use a wet filter.

FILTER REPLACEMENT

1. Insert the panel filter.
2. Install the shaker motor assembly.
3. Install and tighten the four filter retaining knobs.
4. Hook the wire harness to the filter shaker motor.
5. Close the hopper cover and secure the latches.

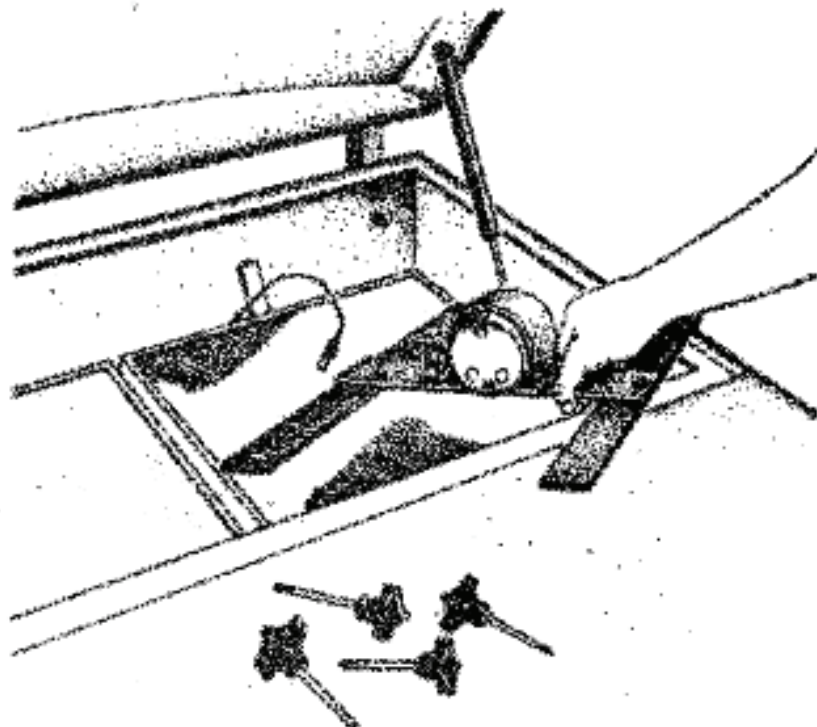

HOPPER FLOOR CLEARANCE AND DUMP ADJUSTMENTS

In order to perform properly, the hopper (on both low and high dump models) must maintain a clearance of 3-1/2" from the floor to the rear hopper entrance lip. The front of the hopper should be adjusted so that the front bumper aligns with the hopper frame where the two meet. When properly adjusted, the front edge of the hopper will be 5" to 6" from the floor.

Low Dump Models:

1. Park the machine on a level surface, shut off the engine, and engage the parking brake.
2. Adjust the two hex bolt stops, located on the frame under the middle of the lift arms, so that the hopper lip is about 3-1/2" from the floor. This is a coarse adjustment.

NOTE: A 3 to 4 foot length of dressed 2 x 4 lumber set on edge works well for this measurement.

3. Use the set screws located in the lift arm flanges located at the rear of each lift arm as a fine adjustment to achieve the 3-1/2" clearance.
4. Check the floor clearance on each side of the hopper to see that it is level from side to side.

NOTE: If after the initial adjustment the bumper is lower or higher than the frame, raise or lower the hex bolt stops until it is level with the frame. Then readjust the set screws to restore the 3-1/2" floor clearance.

NOTE: A balanced adjustment of both of these sets of screws is required to achieve correct hopper position.

5. After adjustment, check that hopper vacuum seal still contacts and seals against rear of hopper. If not, readjust hopper seal.
6. Lower the hopper.

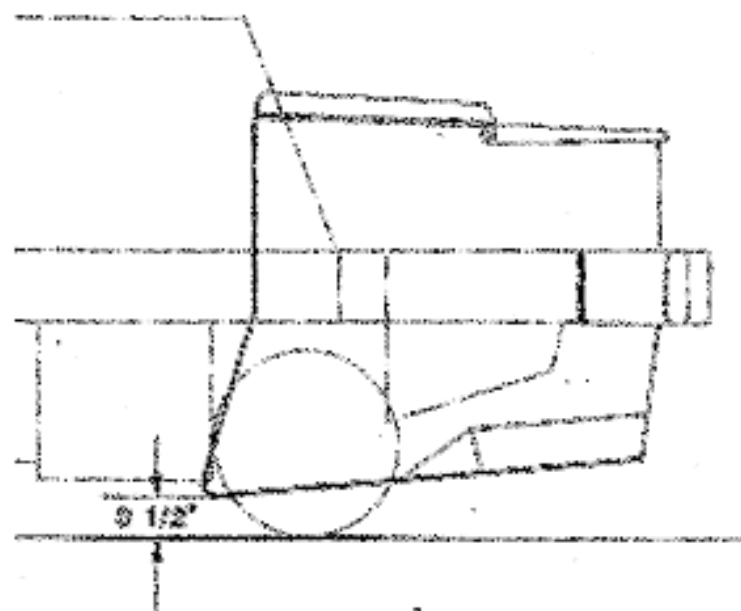

ADJUSTING MAXIMUM HOPPER DUMP ANGLE

Low Dump Models

NOTE: By observing the cylinder strokes, you can determine if maximum stroke (maximum hopper dump angle) is being achieved and then make necessary adjustments. Unpainted exposed portion of the cylinder rods when hopper is down indicates a loss of stroke.

1. With the hopper lowered, with correct floor clearance, note the amount of unpainted cylinder that does not return into the cylinder bodies.
2. If more than 1/8" of unpainted cylinder rod is exposed on both cylinders, then the hopper dump angle can be increased by the following:
3. Start the engine, raise the hopper and lock the lift lever in full RAISE position.
4. Turn off the engine.
5. Loosen the set screw on each of the cylinder clevises and adjust each side alternately. With a tapered punch, rotate the cylinder rod to thread it out of the clevis a distance equal to the length of exposed rod on the cylinder observed when the hopper was down.
6. Tighten the set screws.
7. Lower the hopper.
8. Check to see that both lift arms rest on the hex bolt steps and are not held off the steps by the retracted cylinders.
9. Raise the hopper to ensure that both the cylinders reach their extended positions at the same time. If not, screw in the clevis on the longer cylinder to match the other cylinder's extended length.

High Dump Models

1. Park the machine on a level surface, shut off the engine, and engage the parking brake.

CAUTION: Do not rely upon hydraulic cylinders to keep hopper raised for maintenance on high dump models. Always engage the safety arm before getting under the hopper.

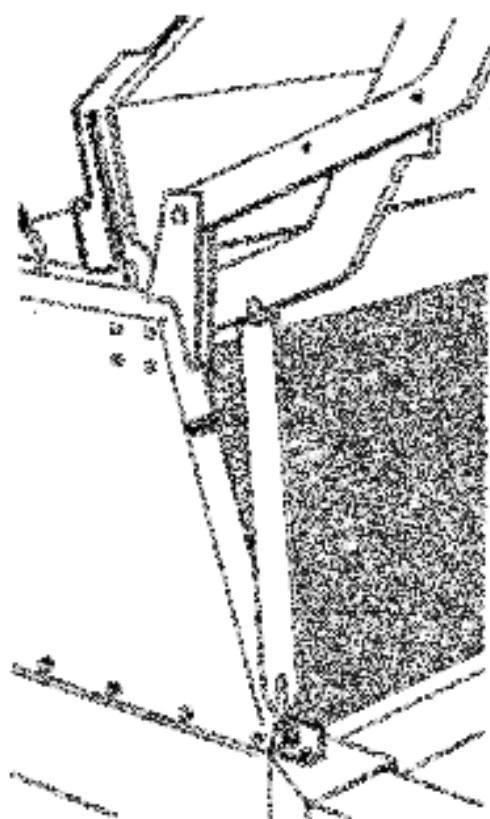

2. Adjust the lift arm stop bolts located on top of the wheel wells as low as possible while still allowing the side beam assembly to clear the lift arms when the hopper is in normal position. Be sure that both lift arms contact the stop bolts at the same time.

NOTE: This may involve raising and lowering the hopper several times.

3. After adjustment, with the hopper down, use the two adjustable stops located on the rotation plates on both sides of the hopper to establish 3-1/2" clearance between the rear hopper entrance lip and and the floor.

NOTE: The stop on the driver's side is located immediately below the cylinder rod end and is threaded into the cylinder mount arm. The stop on the left side is located directly above the arm rotation pins.

(Continued on next page.)

4. After the 3-1/2" clearance is established, make sure both stops make contact simultaneously. The lower front edge of the hopper should be 5" - 6" from the floor. A balanced adjustment of both sets of adjustment bolts is required to correctly adjust the hopper in the lowered position. If the bumper is lower than the frame, after the hopper is correctly adjusted, loosen the bumper attachment bolts and reposition the front bumper.
5. Next, raise the hopper and rotate fully.
6. Turn the engine off.

CAUTION: Do not rely upon hydraulic cylinders to keep hopper raised for maintenance on high dump models. Always engage safety arm before getting under the hopper.

7. Adjust the stops on the hopper mounts on each side of hopper so that clearance between the lift arms and the cut outs in bumper is 1/4" maximum.
8. Loosen the locking set screw in the bottom side of the rotation cylinder rod end.
9. Using the hole in the cylinder rod, turn the rod to adjust cylinder extended length to match hopper rotation stops.
10. Tighten the set screws.
11. Rotate the hopper back, remove the safety arm, and lower the hopper.

HOPPER VACUUM GASKET MOUNT ADJUSTMENT

1. With hopper in normal position, observe contact between back of hopper and gasket. If complete seal is not maintained, remove low dump hopper or raise high dump hopper.

CAUTION: Do not rely on hydraulic cylinders to keep the hopper raised for maintenance on high dump models. Always engage the safety arm before getting under the hopper.

2. Loosen mounting bolts in gasket mount. Move assembly toward hopper. Tighten bolts. Test and repeat if necessary.

HOPPER FLAP REPLACEMENT

Flaps located at the entrance lip of the hopper, and on the sides of the hopper, must be replaced when worn or damaged. The flap panels may be replaced separately.

1. Park the machine on a level surface and engage the parking brake.
2. Raise (high dump models) or remove (low dump models) the hopper.

CAUTION: Do not rely on hydraulic cylinders to keep the hopper raised for maintenance on high dump models. Always engage the safety arm before getting under the hopper.

3. Turn off the engine.
4. Remove the flap retaining angle and worn or damaged flaps.
5. Install new flaps.
6. Replace the retaining angle.

HOFFERFRAME SEAL REPLACEMENT

Front Frame Seal

The hoffer frame seal beds in the front edge of the engine pan. Install a new seal by tacking it in half to edge holes. Double edge with holes goes on bottom. Support the seal straight up while tacking the retainer bar in place. The seal should bed over the retainer bar after installation. Be certain that the seal edges are aligned to prevent binding of the seal.

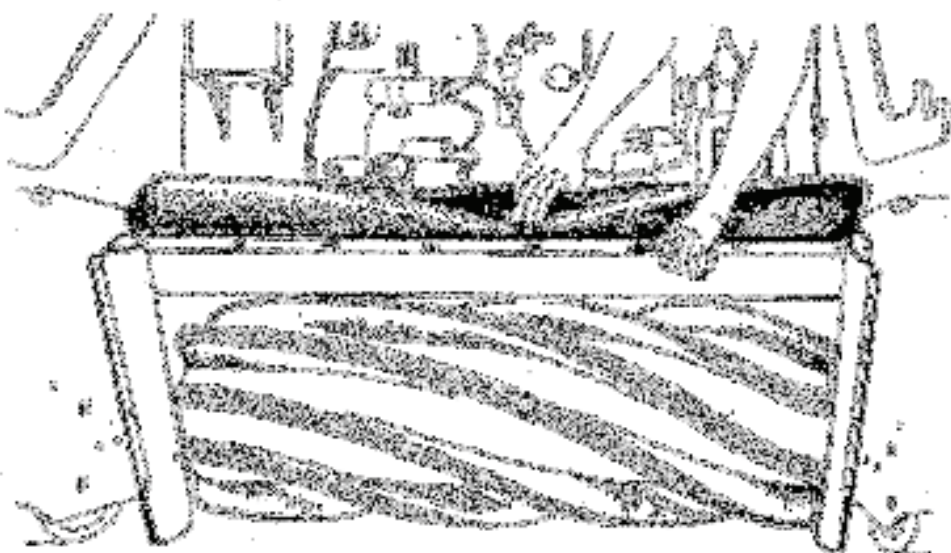

Side Frame Seals

The side frame seals should clear the floor by at least 1/8".

If the bottom of a side seal measures 1/8" or more above the floor, readjust it or replace it by removing the bolts on the inside of the frame wheel wells, installing a new seal, and securing it with the bolts. The double edge with the holes goes toward the track.

STEERING

To keep steering mechanisms safe and efficient, perform the following maintenance:

- Lubricate the grease points on the steering gear box, steering link arm, and steering fork assembly after every 200 hours of operation.
- Check the steering gear box for wear and adjust as needed.

WARNING

Never attempt to perform any service on the equipment or components until the engine is OFF, the parking brake is LOCKED, and the wheels are CHOCKED.

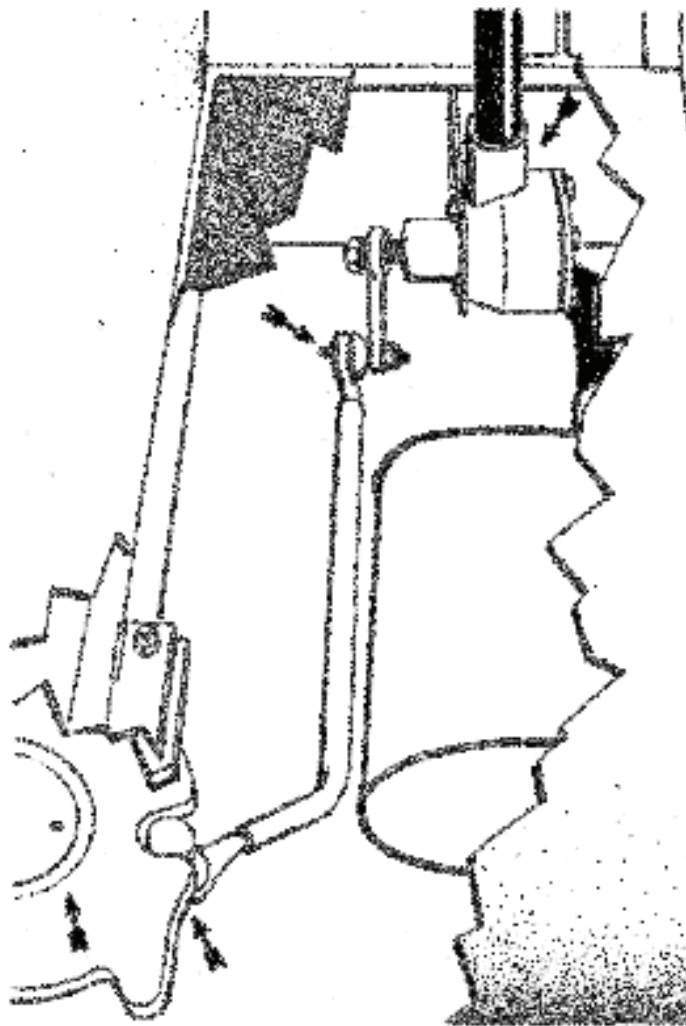

PARKING BRAKE

The parking brake on the sweeper is a set of mechanical drum brakes operated by a cable from the foot pedal. To keep the parking brake functioning safely and efficiently, check to see that it works properly and perform the adjustment explained below when necessary.

SERVICE INSTRUCTIONS

WARNING

Never attempt to perform any service on the equipment or components until the engine is OFF, the parking brake is LOCKED, and the wheels are CHOCKED.

PARKING BRAKE ADJUSTMENT

1. Locate the parking brake cable in the top of the left wheel well opening.
2. Loosen the locking nut located against the hex bar.
3. Thread the cable end as far into the hex bar as needed.
4. If threads are not sufficient for adjustment, move the cable bars to the next adjusting hole on the hex bar.
5. Tighten the locking nut against the hex bar. This adjusts both sets of brake shoes.
6. Test brakes. Readjust if necessary.

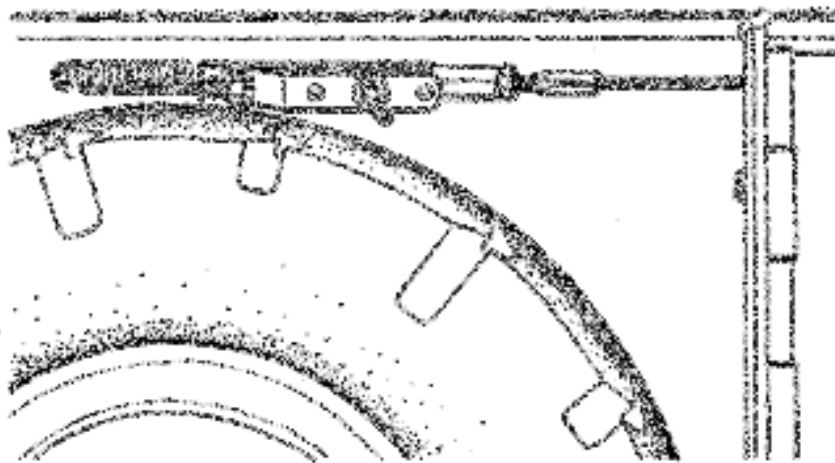

TIRES

PowerBoss™ sweepers use an interchangeable, two-piece, bolt-together cast rim for mounting solid tires. Michelin pneumatic tires require a special three-piece rim. The maintenance requires the following:

- Visually inspect tires every day for wear and damage.
 - Check pneumatic tires for proper air pressure after every 200 hours of operation.
-

SERVICE INSTRUCTIONS

WARNING

Never attempt to perform any service on the equipment or components until the engine is OFF, the parking brake is LOCKED, and the wheels are CHOCKED.

INFLATION

Inflate Michelin pneumatic tires to 145 psi.

CHANGING SOLID TIRES

NOTE: The procedures which follow apply to solid tires only.

1. Remove tire from vehicle by removing the five inner lug nuts.
2. Remove the five flathead bolts and nuts.
3. Press the tire from rim.
4. Press the large rim half into the new tire.
5. Mount the small rim half and secure with flathead bolts.
6. Reinstall tire on machine.

CHANGING PNEUMATIC TIRES

Since procedures for changing Michelin tires must be performed in a safety cage and require special tools, we recommend you have these tires changed by a professional tire dealer.

MISCELLANEOUS ADJUSTMENTS

- Each machine is equipped with an anti-static drag chain bolted to the back wall of the boom chamber. This should remain in contact with the floor at all times. Inspect the chain every 200 hours. Replace if at least one link does not drag the surface of the floor.
 - Latches and hinges should be inspected after every 500 hours of use. Retighten and oil if necessary.
 - Inspect cables for wear every 500 hours.
-

WARNING

Never attempt to perform any service on the equipment or components until the engine is OFF, the parking brake is LOCKED, and the wheels are CHOCKED.

TABLE OF CONTENTS
Troubleshooting

Basic Machine Operating Problems.....	G-1
Sweeping Problems.....	G-2
Hydraulic System Problems.....	G-4

PROBLEM**CAUSE****SOLUTION****BASIC MACHINE
OPERATING PROBLEMS**

Engine will not start or runs roughly after start.

Battery dead

Recharge or replace battery.

Machine out of fuel

Refuel.

Fuel filter plugged

Clean or replace filter.

Fuel line broken or obstructed

Blow fuel line out with compressed air.

Fuel line connection loose

Tighten connection.

Dirty air filter

Clean or replace air filter. (see Service/Repair Section.)

Problems with spark plugs, ignition points, ignition coil, ignition switch, carburetor, regulator, wiring harness

Review engine manual at back of this book for maintenance and troubleshooting procedures.

NOTE: On machines using LPG Fuel, also check the following:

Tank valve not fully opened

Open the valve slowly.

Fuel tank type does not match fuel supply

Use the correct tank type for the fuel supply.

Fuel tank and lines are frosting up

Open shut-off valve slowly to 1/4 open; start.

Defective oil press switch or solenoid shut off

Replace.

Engine overheats.

Low coolant level.

Supply coolant.

Clogged radiator.

Flush radiator.

Loose fan belt.

Tighten belt.

Defective thermostat.

Replace thermostat.

NOTE: If coolant loss has not occurred, check for malfunction of the temperature sending unit.

PROBLEM	CAUSE	SOLUTION
PowerBoss™ moves slowly or does not move.	Parking brake on	Release brake.
	Directional pedal linkage jammed, damaged, or not adjusted properly	Clear jam or adjust linkage.
	Tires sticking from contact with oil or grease	Clean tires or drive through a solvent removing substance.
	Wheels jammed	Clear jam.
	Low hydraulic oil level	Add oil.
	Hydraulic oil temperature too high and too thin caused by excessive load, clogging, high environment temperatures or worn pump	Use the proper weight of oil for the operation conditions; check pump.
	Damaged or worn pump drive coupling	Replace.
PowerBoss™ creeps in neutral.	Other problems with the hydraulics system: pump failure, motor failure, relief valve leaking or stuck open	See Hydraulics System Problems in this section.
	Directional pedal return spring out of adjustment	Perform the adjustment procedure.

SWEEPING PROBLEMS

Brushes do not turn or turn very slowly.	Hydraulic system problems	See Hydraulics System Problems in this section.
	<ul style="list-style-type: none"> - motor - control valve - gear pump - relief valve 	
Little or no vacuum in brush compartment.	Filters clogged	Clean filters.
	Leak or clog in hose from impeller	Repair leaks; clear obstructions or replace hose.
	Impeller belt slipping due to grease on belt or loose eye	Clean grease from belt or tighten. Re-size if too large.
	Impeller belt worn	Replace belt.
	Impeller failure	Check and repair.

PROBLEM	CAUSE	SOLUTION
Hopper does not rotate or rotates slowly.	Hopper load too heavy Hydraulic system problem: - control valve - gear pump - lift cylinder - relief valve	Dump more frequently. See Hydraulic System Problems in this section.
HYDRAULIC SYSTEM PROBLEMS		
Hopper lift cylinder failure.	Line to cylinder leaking Piston seals leaking Burst piston rod	Tighten fittings or replace hose. Replace seals. Replace rod.
Hydraulic control valve failure.	Misaligned control linkage Foreign matter in spool bore Valve seals leaking O-rings leaking Relief valve stuck open	Align. Remove spool and clean bore. Replace seals. Replace O-rings. Clean or replace relief valve.
Hydraulic motor failure.	Motor leaking Drive link malfunction Gearset worn Output shaft malfunction	Replace seals. Replace drive link. Replace gearset. Replace output shaft and bearings.

PROBLEM**CAUSE****SOLUTION**

Hydraulic gear pump failure.

Pump leaking

Replace seals.

Gears worn or scored

Replace pump.

Relief valve stuck

Clean or replace (if control valve).

Oil supply low

Check and fill.

Oil strainer clogged

Replace strainer (inside reservoir).

Incorrect oil

Use recommended viscosity oil.

Damage due to entry of air into hydraulic system

Maintain correct hydraulic oil level in reservoir. Keep suction hose fittings tight.

Hydraulic variable displacement pump failure

Pump leaking

Replace seals.

Relief valve(s) stuck

Clean or replace relief valve(s).

Drive coupling malfunction

Replace coupling.

Control linkage out of adjustment

Check to see if linkage is binding or unfastened.

Charge pump gears worn or scored

Replace defective gears.

Damage due to entry of air into hydraulic system

Maintain correct hydraulic oil level in reservoir. Keep suction hose fittings tight.

Hydraulic system noisy.

Air in system

Check oil level in reservoir; check for loose connections or leaks.

Relief valve dirty or damaged.

Clean or replace.

Loose suction line

Tighten fittings.

Clogged suction filter or pump inlet line.

Replace filter, clear line; change oil in reservoir if dirty and flush system.

Internal pump or motor damage

Inspect and repair.